

RED LAKE WATERSHED DISTRICT

May 23, 2019

Agenda

3:00 p.m.

3:00 p.m.	Call to Order	Action
	Review and approve agenda	Action
	Requests to appear	Information
	May 9, 2019 Minutes	Action
	May 17, 2019 Minutes	Action
	Financial Report dated May 22, 2019	Action
	2019-2020 League of MN Cities Insurance Policy	Info./Action
	City of Thief River Falls Joint Powers Agreement	Info./Action
	West Polk SWCD-Burnham Creek Funding Request	Info./Action
3:30 p.m.	Bid Opening-Ditch 16, RLWD Project No. 177	Info./Action
	Wetland Delineation (Houston Engineering)	Info./Action
	Brandt Impoundment, RLWD Proj. 60D-Screwgates	Info./Action
	Permit No. 18148, Ray Kvalvog	Action
	Permit No. 18156, Brent Strand	Action
	Permits: No. 19010, 19027-19041, 19045	Action
	Water Quality Equipment-Water Level Loggers	Info./Action
	Engineering Equipment	Info./Action
	Black River Impoundment, RLWD Project No. 176-Update	Information
	Pine Lake Project, RLWD Project No. 26	Info./Action
	Thief River Falls Westside FDR Project, RLWD Project No. 178	Information
	MAWD Summer Tour	Information
	Administrators Update	Information
	Legal Counsel Update	Information
	Managers' updates	Information

Recess to 6:00 p.m. at the Quality Inn for the TRF Westside FDR
Project Hearing, Quality Inn, Thief River Falls

Action

UPCOMING MEETINGS

June 13, 2019

RLWD Board Meeting, 9:00 a.m.

June 26-28, 2019

2019 MAWD Summer Tour

June 27, 2019

RLWD Board Meeting, 9:00 a.m.

DRAFT

RED LAKE WATERSHED DISTRICT
Board of Manager's Minutes
May 9, 2019

President Dale M. Nelson called the meeting to order at 9:00 a.m. at the Red Lake Watershed District Office, Thief River Falls, MN.

Present were: Managers Terry Sorenson, Gene Tiedemann, Brian Dwight, Dale M. Nelson, LeRoy Ose, and Les Torgerson. Absent: Allan Page Staff Present: Myron Jesme and Tammy Audette and Legal Counsel Sparby.

The Board reviewed the agenda. A motion was made by Torgerson, seconded by Tiedemann, and passed by unanimous vote that the Board approve the agenda. Motion carried.

The Board reviewed the April 25, 2019 minutes. Motion by Sorenson, seconded by Dwight, to approve the April 25, 2019 Board meeting minutes as presented. Motion carried.

The Board reviewed the Financial Report dated May 8, 2019. Motion by Ose, seconded by Tiedemann, to approve the Financial Report dated May 8, 2019 as presented. Motion carried.

Staff member Arlene Novak reviewed the Investment Summary dated May 8, 2019. Novak will complete the Capital Projects Fund projection and report back to the Board at a later date.

Engineer Nate Dalager, HDR Engineering, Inc., presented a drone video of flooded cabins on Pine Lake, RLWD Project No. 26. A project team meeting will be held May 17, 2019 a 9:30 a.m. at the District office. Dalager discussed various meetings recently held with staff from MnDNR.

EIT Dillion Nelson, HDR Engineering, Inc., stated that permits will be submitted today to the appropriate agencies, for the Thief River Falls Westside FDR Project, RLWD Project No. 178. Administrator Jesme stated that the District was made aware of potential permitting requirements with the Federal Aviation Administration, due to the proximity of the Thief River Falls Regional Airport. Letters to the landowners within the Watershed Management District, will be sent out today. Jesme has been providing additional information to the appraiser for completion of the appraisal report. Jesme discussed a requirement to have letters served to landowners that the District will need to acquire an easement from. Discussion was held on right of way staking at the lower end of the project, and the ability for local farmers to plant crops within the right-of-way. It was the consensus of the Board, that wheat could potentially be harvested prior to the construction of the project so pre-staking of right of way may not be necessary.

The Red Lake County River Watch students presented their project that they completed for the River Watch Forum, where they were awarded first place.

Discussion was held on changing the May 23, 2019 meeting time to 3:00 p.m., to allow the Board to go directly from the Board meeting to the Thief River Falls Westside FDR Project

hearing, which will be at 6:00 p.m. at the Quality Inn, Thief River Falls. Motion by Dwight, seconded by Ose, to change the May 23, 2019 regularly scheduled Board meeting to 3:00 p.m., on May 23rd to be held at the District office. Motion carried.

Motion by Tiedemann, seconded by Sorenson, to schedule the Ditch 16, RLWD Project No. 177, bid opening for May 23, 2019 at 3:30 p.m. at the District office. Motion carried. Administrator Jesme stated that he received notice that the Polk County Commissioners approved the Bond purchase at an interest rate of 2.83%. Jesme indicated that the archaeological review will need to be completed. District staff completed staking of the right-of-way.

Administrator Jesme stated that he requested an increase in bond from the petitioners for the Improvement to Polk County Ditch 39, RLWD Project No. 179. No additional expenditures will be incurred until the bond is received.

The Thief River 1W1P Policy Committee approved Section 4, which will allow for the assembly of all five sections of the plan, followed by a plan review by the Planning Work Group.

Staff member Corey Hanson updated the Board on the Water Restoration and Protection Strategy (WRAPS) Reports for the Thief River Watershed, Grand Marais Creek Watershed, Red Lake River Watershed, and Clearwater River Watershed, that are wrapping up this year. Hanson stated that WRAPS is a MPCA system for assessing water quality and creating restoration and plans. Hanson discussed the Total Maximum Daily Load (TMDL) Reports he wrote that address impairments and how to restore them. Discussion was held on the tasks that were completed for each WRAPS project, including Civic Engagement processes that were efforts to keep the public informed. Discussion was held on the water quality results found on the Lost River upstream of Pine Lake. Hanson will be collecting extra water quality data on the Lost Lake upstream of Pine Lake in 2019 to characterize pre-project water quality conditions in preparation for a potential FDR project in that area. Hanson noted that the Red Lake DNR took the lead role on the Upper and Lower Red Lake TMDL's; the MPCA is currently reviewing their draft TMDL report. Hanson discussed the public notice contract in the amount of \$7,500 with the MPCA for the Clearwater River Watershed Restoration and Protection Strategy Public Notice, RLWD Project No. 157E. Motion by Tiedemann, seconded by Ose, to approve the public notice contract with the MPCA for the Clearwater River Watershed Restoration and Protection Strategy Public Notice, RLWD Project No. 157E. Motion carried.

The Board reviewed the permits for approval. Motion by Sorenson, seconded by Torgerson, to approve the following permits with conditions stated on the permit: No. 19006, Shannon Blasus, Johnson Township, Polk County; No. 19014, Marshall County Highway Department, Valley Township, Marshall County; No. 19015, Rick Forsberg, Eden Township, Polk County; No. 19016, Polk County Highway Department, Fanny Township, Polk County; No. 19017, Rick Forsberg, Eden Township Polk County; No. 19018, Darrell Payment, Terrebonne and Gervais Township, Red Lake County; No. 19019, Brett Bakken, Equality Township, Red Lake County; No. 19020, Tim Raiter, Wyandotte Township, Pennington County; No. 19021, Tim Raiter, Smiley Township, Pennington County; No. 19022, Jeffrey Olson, Rocksbury Township, Pennington County; No. 19023, Grove Park/Tilden Township, Polk County; No. 19024, North

Township, Pennington County; No. 19025, Earl Pederson, North Township, Pennington County; and No., 19026, Bruce Jones, Goodridge Township, Pennington County. Motion carried.

Motion by Tiedemann, seconded by Dwight, to deny Permit No. 19013, Dan Johnson, Huntsville Township, Polk County. Motion carried.

Staff member Tammy Audette reviewed quotes received from Garden Valley Technologies and Marco for a new telephone system for the District office. Motion by Dwight, seconded by Sorenson, to approve the quote in the amount of \$3,911.00 from Marco, for a new telephone system for the District office. Motion carried.

The Board reviewed quotes for the purchase of a 2019 Chevrolet Silverado from Northern Motors and Thibert's Chevrolet. Sorenson questioned if any other car dealers were contacted for their services. Jesme indicated that he did request a quote from Thief River Ford, but no quote was received. Motion by Ose, seconded by Torgerson, to approve the low quote in the amount of \$36,531.58, from Thibert's Chevrolet for a 2019 Chevrolet Silverado. Motion carried with Manager Sorenson opposed.

Staff member Loren Sanderson stated that he was contacted by April Swenby from the Sandhill River Watershed District regarding a boundary issue located in Onstad Township, Polk County. Sanderson viewed the area with Swenby, noting that Swenby intends to contact MnDOT to request the removal of a culvert. Sanderson noted that the culvert in question was placed two years prior to the revised boundary with Sandhill River Watershed District. The culvert does not contribute to adverse impacts downstream. Sanderson also noted that there are additional culverts on the boundary that enter the RLWD from the Sandhill River Watershed District. Sanderson stated that he will be meeting with MnDOT staff to review the concerns brought up by Swenby. It was the consensus of the Board, to recommend leaving the stated culvert in place, and request MnDOT to review the off-take ditch and clean if necessary.

Staff member Loren Sanderson updated the Board on operation of District impoundments, and release of water from within the impoundments after the spring flood event.

Manager Tiedemann asked about the status of the emergency spillway on the Brandt Impoundment regarding the concerns of landowner Ron Salentine. Staff member Nick Olson stated that he surveyed the emergency spillway and provided the information to HDR Engineering, Inc. Olson noted that it appears the emergency spillway is one foot higher than planned design.

Staff member Loren Sanderson stated that the District tile permit application does not state that the landowner be the applicant. Administrator Jesme stated that the District's Permit Rules and Regulations state that the application should be in the landowner's name, not the renter. Motion by Ose, seconded by Torgerson, to amend the District's tile permit application to comply with the District's rules requiring the landowner to be the applicant. Motion carried.

Legal Counsel Sparby stated that he is working on a Joint Powers Agreement with the City of Thief River Falls for a joint effort for bidding purposes on the Thief River Falls Westside Flood Damage Reduction Project, RLWD Project No. 178.

Legal Counsel Sparby stated that a hearing with the judge will be held later this month for the Judicial Ditch 5, (Four-Legged Lake), RLWD Project No. 102.

Administrators Update:

- Jesme and Manager Ose will attend the RRWMB on May 21, 2019 in Crookston.
- Jesme participated in a Red Lake River 1W1P Planning Workgroup telephone conference on April 30th. The meeting was to review the minor changes to the existing Work Plan and submit to BWSR for approval. Items that were addressed were a bank stabilization project in the Burnham Creek Watershed initiated by the West Polk SWCD. We also clarified funding for the stabilization of the outlet to the Thief River Falls Westside FDR Project.
- Jesme attended a Watershed Based Funding Local Round Table Work Group and BWSR Clean Water Team meeting on April 26th in St. Cloud. Various items were covered such as an overview of Watershed-based funding, Assurance Measures, Watershed based funding policy, desired outcomes and various other agenda items. This meeting was rescheduled from April 12th.

Discussion was held on the fish passage on the Blackduck Lake. Manager Dwight discussed a concern with localized flooding and beaver dams.

Motion by Sorenson, seconded by Ose, to adjourn to the May 17, 2019 Pine Lake Area Project Team meeting at 9:30 a.m. at the Red Lake Watershed District office, 1000 Pennington Avenue South, Thief River Falls, MN 56701. Motion carried.

Terry Sorenson, Secretary

RED LAKE WATERSHED DISTRICT
Board of Manager's Minutes
May 17, 2019
9:30 a.m.

Present were: Managers Brian Dwight, Allan Page, Terry Sorenson, Gene Tiedemann and Les Torgerson. Absent: Dale M. Nelson and LeRoy Ose. Staff present: Myron Jesme, Arlene Novak, and Corey Hanson.

Vice President Gene Tiedemann called the Red Lake Watershed District Board Meeting to order at 9:30 a.m., to allow the Board to participate in the Pine Lake Area Project Work Team meeting.

After the Pine Lake Area Project Work Team meeting concluded, a motion was made by Sorenson, seconded by Dwight, to adjourn the meeting. Motion carried.

Terry Sorenson, Secretary

RED LAKE WATERSHED DISTRICT
Financial Report for May 22, 2019

Ck#	Check Issued to:	Description	Amount
online	EFTPS	Withholding for FICA, Medicare, and Federal taxes	4,252.48
online	MN Department of Revenue	Withholding taxes	790.72
online	Public Employees Retirement Assn.	PERA contributions	2,777.49
online	EFTPS	Withholding for FICA, Medicare, and Federal taxes	536.83
online	MN Department of Revenue	Withholding taxes	79.20
37472	Pennington SWCD	Shoreland Permit Application fee-TR Westside FDR	25.00
37473	Thibert Chevrolet & Buick Co.	2019 Chev. Silverado Legacy pickup w/sales tax & license	36,531.58
37474	Voided		-
37475	Voided		-
37476	Johnnies Café	Meals for FDR Work Group meeting	229.43
37477	Voided		-
37478	Ace Hardware	Shovel, spray foam, auto fuse	31.66
37479	Brault Construction LLC	Snow removal from RLWD Ditch No. 12 ditches	2,500.00
37480	Cenex Credit Card	Gas for vehicles	418.27
37481	David A. Dalager	Mileage for Pine Lake PWT meeting	60.32
37482	The Exponent	Legal ad for bid opening-RLWD Ditch No. 16	322.24
37483	Further	Flex Spending account monthly fees	8.85
37484	Garden Valley Technologies	Monthly telephone maintenance	125.25
37485	Corey Hanson	Reimburse for UPS shipping of water quality equipment	17.93
37486	HDR, Inc.	Engineering fees for Pine Lake FDR Proj.	1,164.87
37487	Brent Hemly	Remove 10 beaver from Moose River Impoundment	750.00
37488	Houston Engineering, Inc.	Engineering fees for Black River Impoundment	21,859.50
37489	Juane Johnson	Mileage and meal for Pine Lake PWT meeting	78.10
37490	MCI	Long distance telephone expense	74.48
37491	Donald Dornbusch/Northern Lath Co.	15 bundles each of 36" and 48" lath w/delivery charge	382.50
37492	Northwest Beverage, Inc.	H2O for office	29.75
37493	Pennington County Sheriff's Office	Serve letters to 8 landowners in TR Westside FDR Proj.	400.00
37494	Quill Corporation	Labels,pens, clipboard,ruled pads, binder clips, refill lead,etc.	161.27
37495	Rinke Noonan	Legal fees for Thief River Westside FDR Proj.	986.00
37496	RMB Environmental Laboratories	Lab analysis of water quality samples	651.00
37497	Larry Skala	Mileage for Pine Lake PWT meeting	63.80
37498	Sun Life Financial	Life insurance premium	144.64
37499	Thief River Ford	Oil change and tire rotation on 2011 Ford pickup	83.41
online	Further	Medical FSA	44.08
direct	Aflac	Staff paid insurances	613.46
direct	Cardmember Services	* See below for explanation	2,193.29
	Payroll		
	Check #11664-11671		13,448.48
	Total Checks		\$ 91,835.88

*** Cardmember Services**

AT&T cell phone expense	303.31
The Big Green box-recylce batteries	63.00
YSI-Water quality equip.repairs	1,705.00
Holiday In-St. Cloud-Myron	<u>121.98</u>
Total	2,193.29

Banking**Northern State Bank**

Balance as of May 8, 2019	\$ 178,815.94
Total Checks Written	(91,835.88)
Receipt #414548 Transfer in from American Federal Bank	50,000.00
Balance as of May 22, 2019	<u>\$ 136,980.06</u>

Border State Bank

Balance as of March 31, 2019	\$ 18,223.86
Receipt #414533 Border State Bank-Monthly interest	8.12
Balance as of April 30, 2019	<u>\$ 18,231.98</u>

American Federal Bank-Fosston

Balance as of May 8, 2019	\$ 2,155,655.48
Receipt #414537 Daniel/Joyce Wallace-Annual rent for Brandt Impoundment	102.00
Receipt #414539 Thibert Chev. Buick-Reimburse for fees on 2019 Chev. Pickup	3.25
Receipt #414540 Nicholas Knott-2019 Land rent-Black River Impoundment	28,528.56
Receipt #414541 Red Lake County-2019 Riparian Aid	10,995.00
Receipt #414542 Garden Valley Technologies-Patronage dividend	11.46
Receipt #414543 Garden Valley Technologies-Patronage dividend	76.08
Receipt #414544 Garden Valley Technologies-Patronage dividend	4.69
Receipt #414545 Garden Valley Technologies-Patronage dividend	12.51
Receipt #414546 Clearwater County-Riparian aid	23,513.00
Receipt #414547 Craig Stroot-2019 Land rent Parnell	4,243.80
Receipt #414548 Transfer tto Northern State Bank	(50,000.00)
Balance as of May 22, 2019	<u>\$ 2,173,145.83</u>

Receipt #414538 Ultima Bank-Fosston To record interest applied to CD

League of Minnesota Cities Insurance Trust
Group Self-Insured Workers' Compensation Plan
145 University Avenue West St. Paul, MN 55103-2044 Phone (651) 215-4173

Notice of Premium Options for Standard Premiums of Less than \$25,000

RED LAKE WATERSHED DISTRICT
 1000 PENNINGTON AVE S
 THIEF RIVER FALLS, MN 56701-4013

Agreement No.: WC 1003703_Q-3
 Agreement Period:
 From: 07/12/2019
 To: 07/12/2020

Enclosed is a quotation for workers' compensation deposit premium. **Note: Renewal Coverage will be bound as per the expiring coverage arrangement, including coverage for elected and appointed officials, with the premium indicated on the quote, unless the member or agent sends a written request not to bind renewal coverage.**

<u>PAYROLL DESCRIPTION</u>	<u>CODE</u>	<u>RATE</u>	<u>ESTIMATED PAYROLL</u>	<u>DEPOSIT PREMIUM</u>
----------------------------	-------------	-------------	--------------------------	------------------------

SEE ATTACHED SCHEDULE FOR DETAILS

	Manual Premium		3,573
Credit		0.90	-357
	Standard Premium		3,216
	Deductible Credit	0.00%	0
	Premium Discount		0
	Net Deposit Premium		3,216

Agent:
 00985 Northern State Agency
 Po Box 639
 Thief River Falls, MN 56701-0639

Notice of Premium Options for Standard Premiums of Less than \$25,000 (Con't)

OPTIONS

Please indicate below the premium option you wish to select. You may choose only one option and you cannot change options during the agreement period.

NET DEPOSIT PREMIUM

1. **Regular Premium Option**

3,216

2. **Deductible Premium Option**

Deductible options are available in return for a premium credit applied to your estimated standard Premium of \$ 3,216. The deductible will apply per occurrence to paid medical costs only. There is no aggregate limit.

	<u>Deductible per Occurrence</u>	<u>Premium Credit</u>	<u>Credit Amount</u>	<u>Net Deposit Premium</u>
<input type="checkbox"/>	\$250	1.00%	-32	3,184
<input type="checkbox"/>	\$500	1.70%	-55	3,161
<input type="checkbox"/>	\$1,000	2.90%	-93	3,123
<input type="checkbox"/>	\$2,500	5.00%	-161	3,055
<input type="checkbox"/>	\$5,000	7.50%	-241	2,975
<input type="checkbox"/>	\$10,000	10.50%	-338	2,878
<input type="checkbox"/>	\$25,000	17.00%	-547	2,669
<input type="checkbox"/>	\$50,000	22.50%	-724	2,492

This quotation is for a deposit premium based on your estimate of payroll and selected options. Your final actual premium will be computed after an audit of payroll subsequent to the close of your agreement year and will be subject to revisions in rates, payrolls and experience modification. While you are a member of the LMCIT Workers' Compensation Plan, you will be eligible to participate in dividend distributions from the Trust based upon claims experience and earnings of the Trust.

If you desire the coverage offered above, please return this signed document for the option you have selected.

This quotation should be signed by an authorized representative of the city requesting coverage.

Signature
Title
Date

**Notice of Premium Options for Standard Premiums of Less than \$25,000
(Con't)**

CONTINUATION SCHEDULE FOR QUOTATION PAGE

<u>REMUNERATION</u>	<u>RATE</u>	<u>CODE</u>	<u>DESCRIPTION</u>	<u>EST. PREM</u>
204,000	0.72	8810	CLERICAL OFFICE EMPLOYEES NOC	1,469
325,000	0.62	9410	MUNICIPAL EMPLOYEES	2,015
18,200	0.49	9411	ELECTED OR APPOINTED OFFICIALS	89
Manual Premium				3,573

RESOLUTION NO. _____

RESOLUTION APPROVING RED LAKE WATERSHED DISTRICT JOINT POWERS AGREEMENTS WITH THE CITY OF THIEF RIVER FALLS, MN

WHEREAS, the City of Thief River Falls, MN, desires to enter into a Joint Powers Agreements with the Red Lake Watershed District in order to allow them to bid the City's wastewater force main project and storm sewer project as part and parcel with the District's bidding of the TRF Westside FDR project.

NOW, THEREFORE, BE IT RESOLVED by the Red Lake Watershed District, as follows:

1. That the City shall provide at its own cost and expense all necessary plans and specifications and any other information necessary for the planned bidding documents for the wastewater force main project; and shall be responsible for the cost and expense of all necessary plans and specifications and any other information necessary for the planned bidding documents for the storm sewer project designed and administered by the Red Lake Watershed District.
2. That the planned bidding documents shall be provided to the City's Public Works Director and Water Systems Superintendent for review and approval.
3. That after bidding and acceptance of the lowest responsible bidder, the City shall be responsible for all costs and expenses involved in the construction of its portion of the supplied bid plans and specifications and shall be responsible, either by itself or through its hired representatives or agents, for all inspection and testing for the wastewater force main project; and shall be responsible for the cost and all expense for the Red Lake Watershed inspection and testing for the storm sewer project.
4. Joint Powers Agreement by and between the Red Lake Watershed District and the City of Thief River Falls, MN, is hereby approved.
5. That the President or Administrator of the Red Lake Watershed District are designated the Authorized Representative for the District. The Authorized Representative is also authorized to sign any subsequent amendment or agreement that may be required by the Red Lake Watershed District or the City.
6. That Dale Nelson, President, or Myron Jesme, Administrator, are authorized to sign the Red Lake Watershed District Joint Powers Agreement.

Passed and Adopted by the Red lake Watershed District on this _____ day of May, 2019.

RED LAKE WATERSHED DISTRICT

By: Dale Nelson
Its: President

ATTEST: _____
By: Myron Jesme
Its: Administrator

BURNHAM CREEK RUSSIA 13 PROJECT

GRADE STABILIZATION

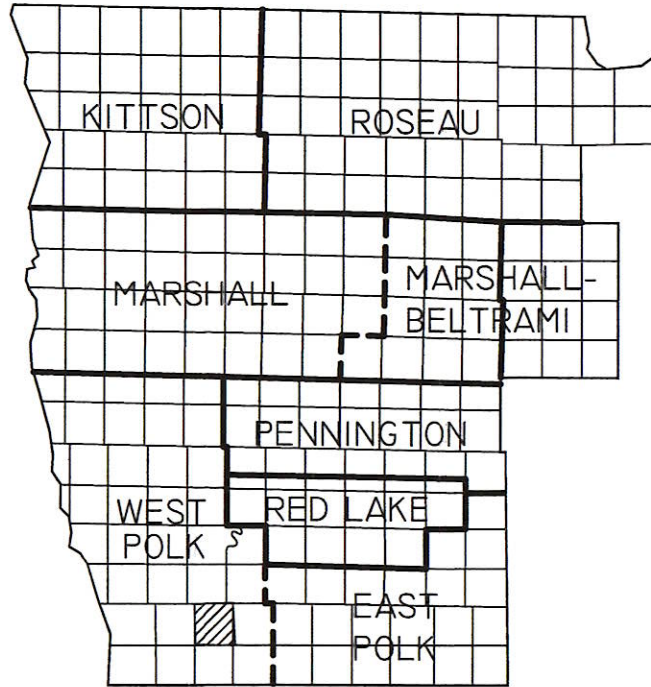

DNR PUBLIC WATERS



BEFORE START OF CONSTRUCTION, THE OWNERS OF ANY UTILITIES INVOLVED MUST BE NOTIFIED. THE EXCAVATOR IS RESPONSIBLE FOR GIVING THIS NOTICE BY CALLING "GOPHER STATE ONE-CALL" AT (651) 454-0002 (TWIN CITIES METRO AREA) OR (800) 252-1166 (ALL OTHER LOCATIONS) AT LEAST 48 HOURS PRIOR TO ANY EXCAVATION.

THE OWNER IS RESPONSIBLE FOR OBTAINING LAND RIGHTS AND ALL PERMITS OR OTHER PERMISSION NECESSARY TO PERFORM AND MAINTAIN THE PROJECT.

-- GOVERNING SPECIFICATIONS --

THE CONSTRUCTION AND MATERIALS SPECIFICATIONS PREPARED FOR THIS PROJECT SHALL GOVERN. THESE SPECIFICATIONS ARE PART OF THE PLAN.

CHANGES IN THE DRAWINGS OR SPECIFICATIONS MUST BE AUTHORIZED BY THE OWNER AND THE RESPONSIBLE ENGINEER. THE OWNER IS RESPONSIBLE FOR CONTACTING THE RED RIVER CONSERVATION SERVICE AREA AND THE WEST POLK SOIL & WATER CONSERVATION DISTRICT AT LEAST 48 HOURS PRIOR TO ANY EXCAVATION.

SHEET INDEX	
SHEET NO.	TITLE
1	SHEET INDEX, LEGEND, & LOCATION MAP
2	PLAN
3	PROFILE
4	ROCK RIPRAP CHUTE
5	DOWNSTREAM ROCK PROTECTION & BALE CHECK
6	SIDE-WATER INLET

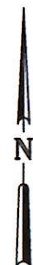

LEGEND

- | | |
|-------------------------------------|---------------|
| SURVEY POINT _____ | △ INST.#1 |
| SOIL BORING _____ | ● TH#1 |
| BUILDING _____ | □ |
| WELL _____ | ○ WELL |
| BENCH MARK, TEMPORARY _____ | ◆ TBM#1 |
| ORIGINAL GROUND _____ | -----90----- |
| CONTOUR, INDEX _____ | - - - - - |
| FENCE, EXISTING _____ | - x - x - |
| FENCE TO BE CONSTRUCTED _____ | - l - l - |
| FENCE TO BE REMOVED _____ | - [] - [] - |
| DIVERSION _____ | ~~~~~ |
| STREAM _____ | ~~~~~ |
| MARSH _____ | ▲▲▲▲ |
| COMMON EXCAVATION _____ | ⊕ |
| EARTHFILL, CLASS C COMPACTION _____ | ⊙ |
| EXISTING TILE LINE _____ | ○ ○ |
| PLANNED TILE LINE _____ | ○ ○ |
| CENTERLINE OF IMPROVEMENTS _____ | —+— |
| CATCH POINTS _____ | |
| DECIDUOUS TREE _____ | ⊙ |
| CONIFEROUS TREE _____ | ⊙ |
| IRON PIPE _____ | ⊙ |
| EMBANKMENT _____ | ⊙ |
| RIPRAP _____ | ⊙ |
| UTILITY POLE _____ | ⊙ |

T 148 N R 46 W
SECTION 13

LOCATION MAP

I hereby certify that this plan, specification, or report was prepared by me or under my direct supervision and that I am a duly Licensed Professional Engineer under the laws of the State of Minnesota.

JAMES HEST
Signature: *James Hest*
Date: 4/21/19 Reg. No. 24511

SHEET INDEX, LEGEND AND LOCATION MAP

West Polk Soil & Water Conservation District
Polk County, Minnesota

PREPARED BY
RED RIVER VALLEY CONSERVATION SERVICE AREA
P.O. Box 16 GRYGLA, MINNESOTA 56727 (218) 294-6142

Drawn by JAH Checked by JAH Date 04-02-19 Sheet 1 of 6



ESTIMATED QUANTITIES		
Quantities are measured in place according to neat-line shown on the plans. No allowance is made for shrinkage, overlapping, connecting bands, joints, etc.		
ITEM	QUANTITY	UNIT
Compacted Earth Fill (Class C)	205	Cu. Yd.
Excavation	5600	Cu. Yd.
Seeding, Fertilizing and Mulching	4	Acres
Rock Riprap MNDOT Class III W/Geotextile	545	Cu. Yd.
18" CMP	30	FT.
18" Steel Apron	1	Each
Bale Checks	3	Each

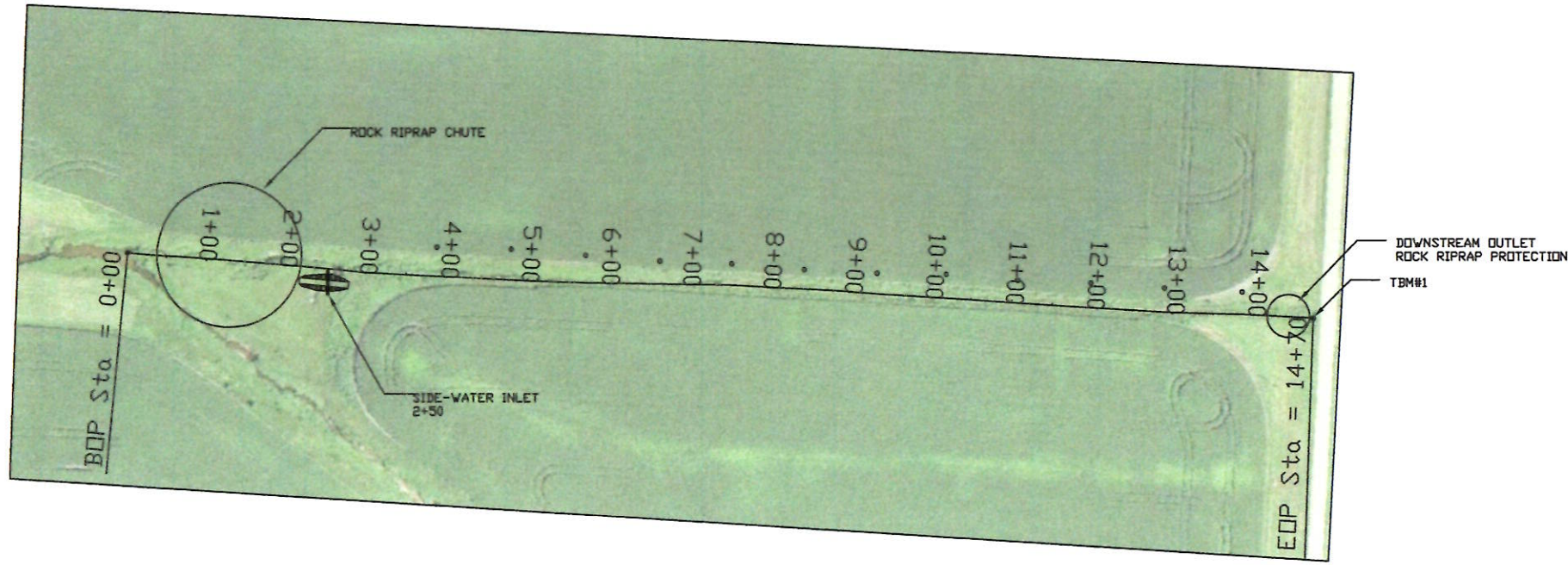

NOTE:
CONTRACTOR SHALL PLACE ALL EXCESS EXCAVATED MATERIAL ON SOUTH SIDE OF DITCH OR AS DIRECTED BY ENGINEER.

PLAN VIEW

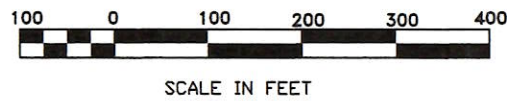

TBM#1 DESCRIPTION, ELEV.= 928.7 FT.
TOP OF 6" DIA. CMP, WEST SIDE

BURNHAM CREEK RUSSIA 13 PROJECT
GRADE STABILIZATION

I hereby certify that this plan, specification, or report was prepared by me or under my direct supervision and that I am a duly Licensed Professional Engineer under the laws of the State of Minnesota. JAMES HEST SIGNATURE: <i>James Hest</i> Date: <u>4/2/19</u> Reg. No. 24511	PLAN AND QUANTITIES <i>West Polk Soil & Water Conservation District Polk County, Minnesota</i>
	PREPARED BY RED RIVER VALLEY CONSERVATION SERVICE AREA P.O. BOX 16 GRYGLA, MINNESOTA 56727 (218) 294-6142 Drawn by JAH Checked by JAH Date 04-02-19 Sheet 2 of 6

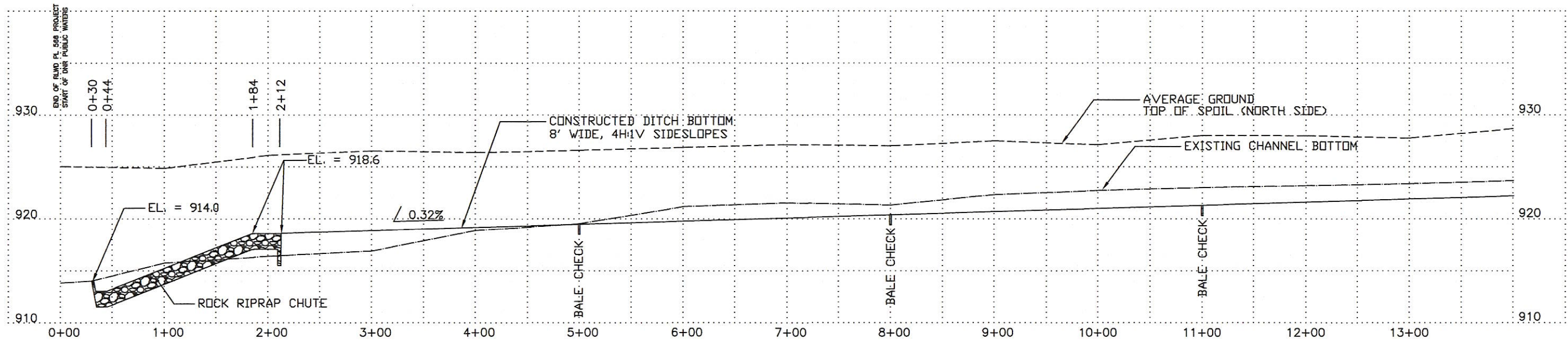

PROFILE

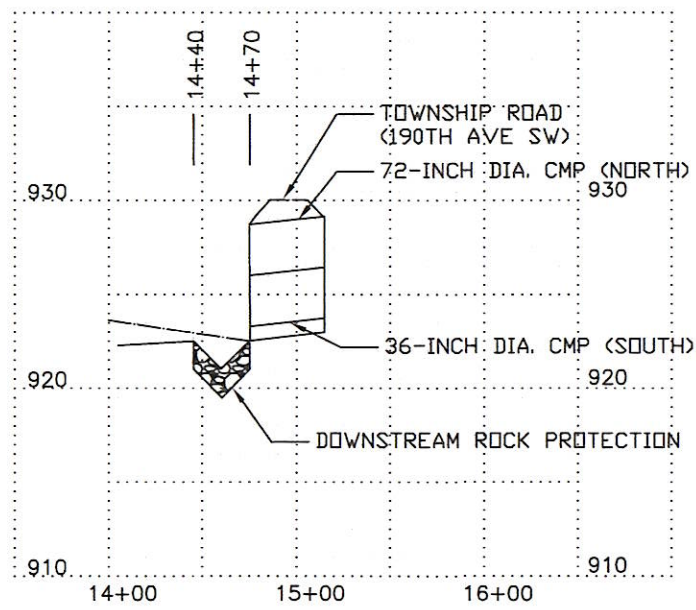

PROFILE

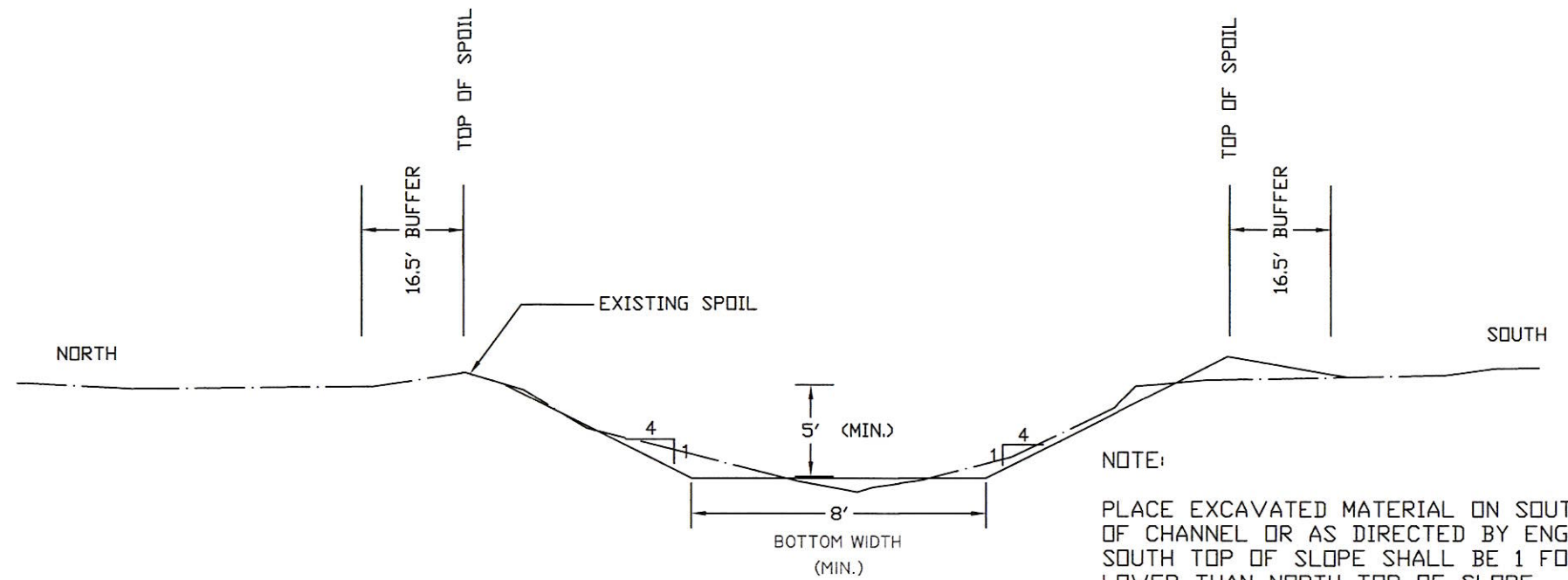

TYPICAL X-SECTION

NOTE:
PLACE EXCAVATED MATERIAL ON SOUTH SIDE OF CHANNEL OR AS DIRECTED BY ENGINEER. SOUTH TOP OF SLOPE SHALL BE 1 FOOT LOWER THAN NORTH TOP OF SLOPE.

BURNHAM CREEK RUSSIA 13 PROJECT
GRADE STABILIZATION

I hereby certify that this plan, specification, or report was prepared by me or under my direct supervision and that I am a duly Licensed Professional Engineer under the laws of the State of Minnesota.

JAMES HEST
Signature: *James Hest*
Date: *4/2/19* Reg. No. 24511

PROFILE

West Palk Soil & Water Conservation District
Palk County, Minnesota
PREPARED BY
RED RIVER VALLEY CONSERVATION SERVICE AREA
P.O. BOX 16 GRYGLA, MINNESOTA 56727 (218) 294-6142
Drawn by JAH Checked by JAH Date 04-02-19 Sheet 3 of 6

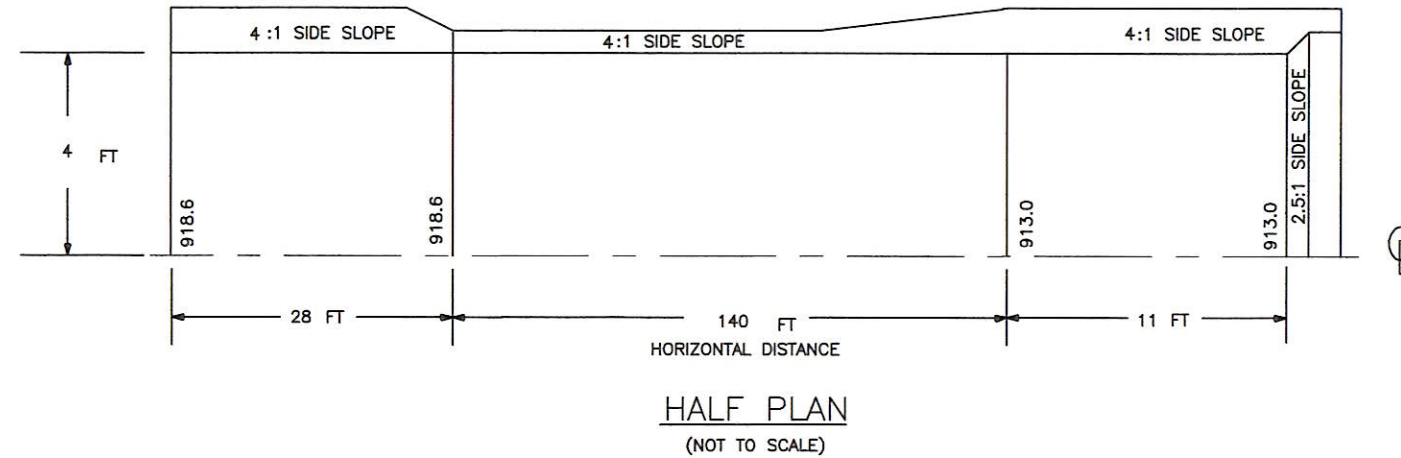
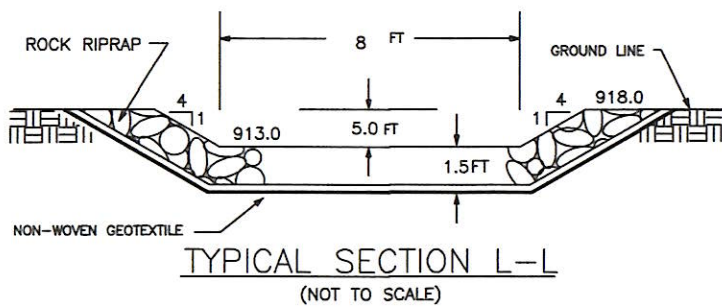
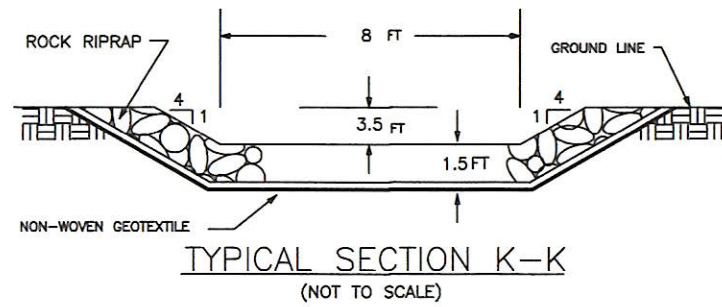
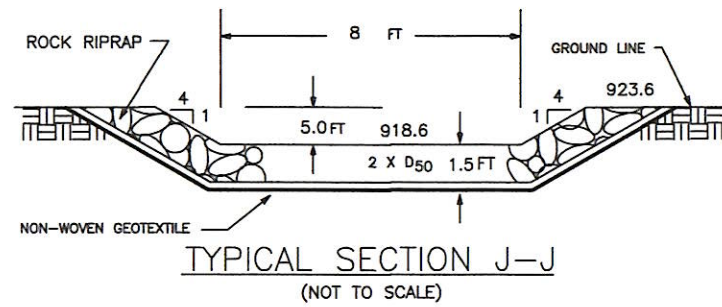
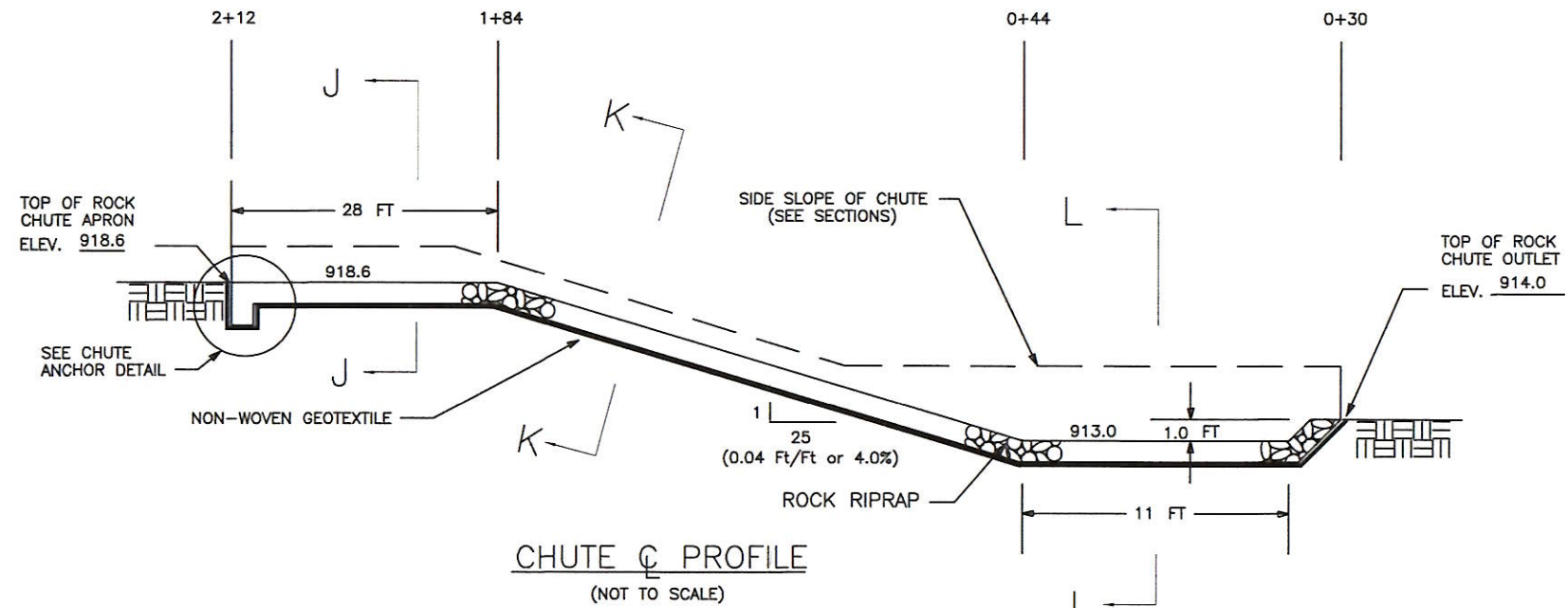
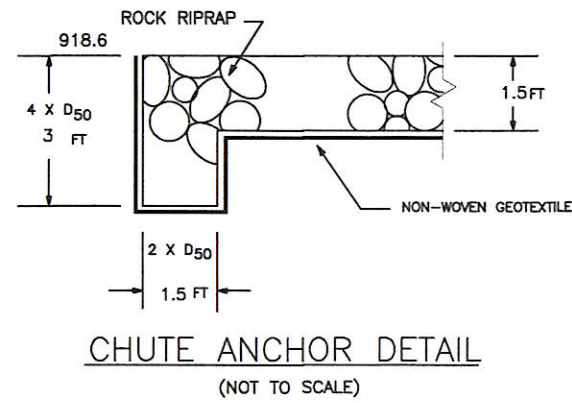

CHUTE STANDARD ROCK GRADATIONS

ROCK RIPRAP SHALL MEET THE REQUIREMENTS OF MN-DOT STANDARD SPECIFICATIONS CLASS IV ROCK RIPRAP

CONSTRUCTION NOTES

1. GEOTEXTILE AND ROCK SHALL NOT BE PLACED UNTIL THE SUBGRADE SURFACE HAS BEEN INSPECTED AND APPROVED BY THE ENGINEER OR ENGINEER'S REPRESENTATIVE.
2. ROCK RIPRAP SHALL MEET THE REQUIREMENTS OF NRCS CONSTRUCTION SPECIFICATION MN-61.
3. ROCK PLACEMENT SHALL BEGIN AT THE BOTTOM OF SLOPE.
4. ROCK SHALL NOT BE DROPPED MORE THAN 3 FT. ONTO GEOTEXTILE.
6. A SUFFICIENT AMOUNT OF ROCK SHALL BE HAND PLACED TO SECURE CONTACT BETWEEN STONES AND INSURE A NEAT, UNIFORM SURFACE.

MATERIALS NOTES

1. GEOTEXTILE SHALL BE NON-WOVEN, CLASS I, AND MEET THE REQUIREMENTS OF NRCS MATERIAL SPECIFICATION MN-592.
2. ROCK RIPRAP SHALL MEET THE REQUIREMENTS OF NRCS MATERIAL SPECIFICATION MN-523, ROCK FOR RIPRAP.

BURNHAM CREEK RUSSIA 13 PROJECT
GRADE STABILIZATION

ROCK RIPRAP CHUTE

West Polk Soil & Water Conservation District
West Polk County, Minnesota

PREPARED BY
RED RIVER VALLEY CONSERVATION SERVICE AREA
P.O. BOX 16 GRYGLA, MINNESOTA 56727 (218) 294-6142

I hereby certify that this plan, specification, or report was prepared by me or under my direct supervision and that I am a duly Licensed Professional Engineer under the laws of the State of Minnesota.

JAMES HEST

SIGNATURE: *James Hest*

Date: 4/2/19 Reg. No. 24511

Drawn by JAH Checked by JAH Date 4-02-19 Sheet 4 of 6

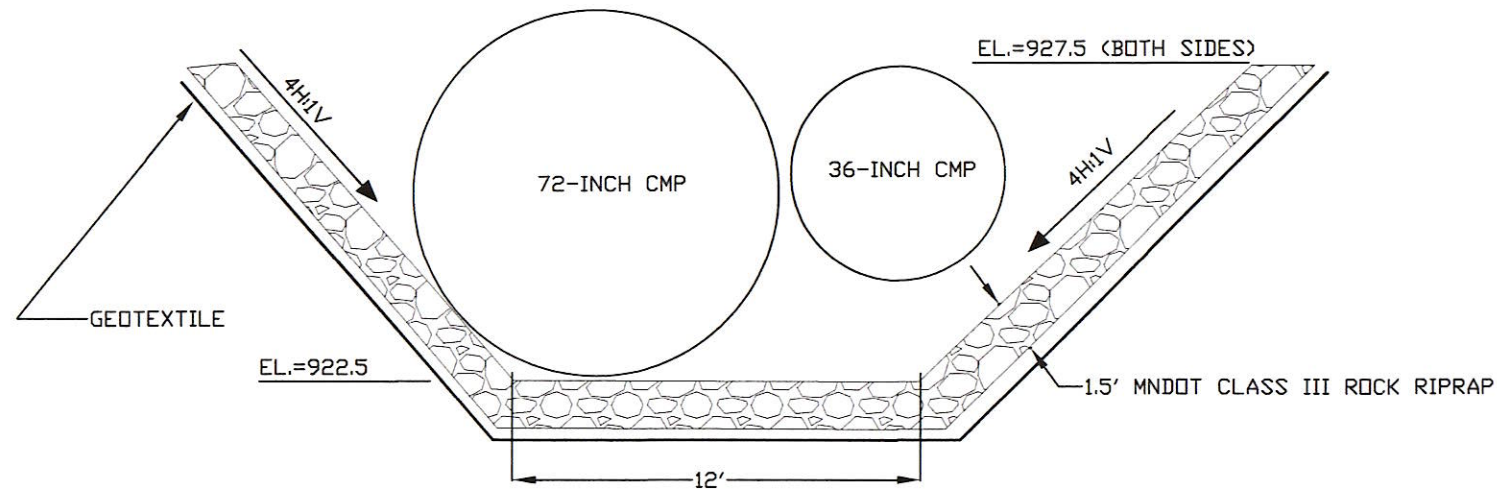

DOWNSTREAM ROCK PROTECTION X-SECTION 14+70

NOT TO SCALE

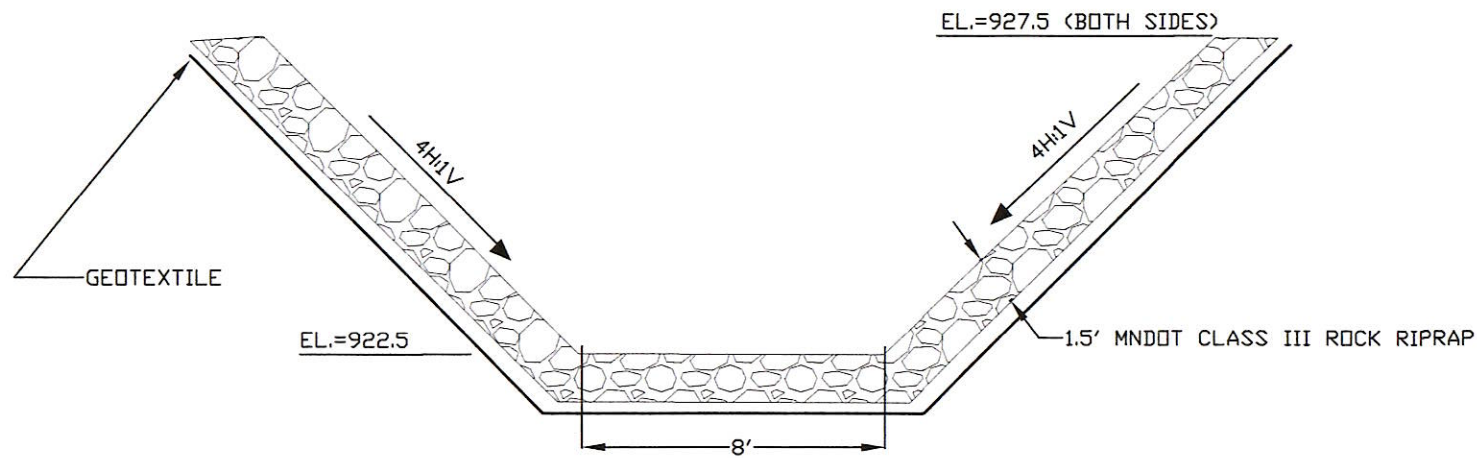

DOWNSTREAM ROCK PROTECTION X-SECTION 14+40

NOT TO SCALE

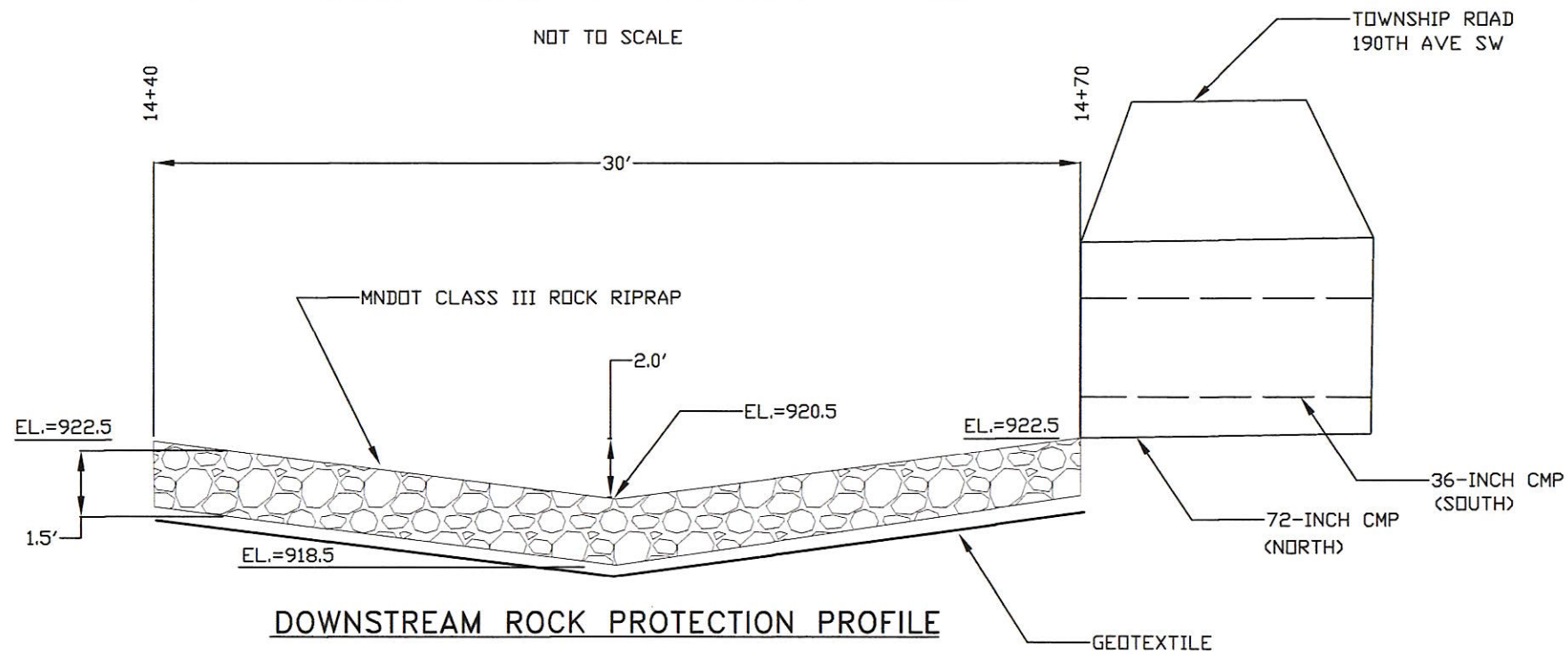

DOWNSTREAM ROCK PROTECTION PROFILE

NOT TO SCALE

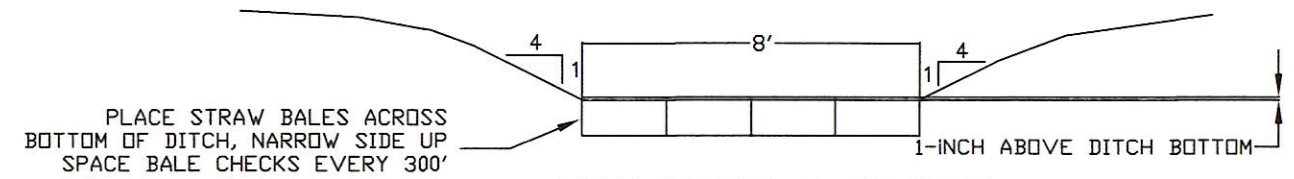

BALE CHECK X-SECTION

NOT TO SCALE

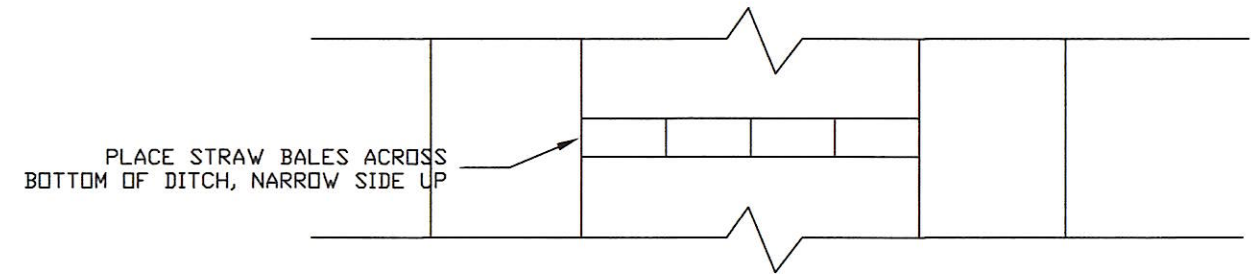

BALE CHECK PROFILE

NOT TO SCALE

NOTE:
PLACE BALE CHECKS AT STATIONS 5+00, 8+00 AND 11+00

I hereby certify that this plan, specification, or report was prepared by me or under my direct supervision and that I am a duly Licensed Professional Engineer under the laws of the State of Minnesota.

JAMES HEST
Signature: *James Hest*
Date: *4/2/19* Reg. No. 24511

BURNHAM CREEK RUSSIA 13 PROJECT
GRADE STABILIZATION

**DOWNSTREAM ROCK PROTECTION
& BALE CHECK**

West Polk Soil & Water Conservation District
Polk County, Minnesota

PREPARED BY
RED RIVER VALLEY CONSERVATION SERVICE AREA
P.O. BOX 16 GRYGLA, MINNESOTA 56727 (218) 294-6142
Drawn by JAH Checked by JAH Date 04-02-19 Sheet 5 of 6

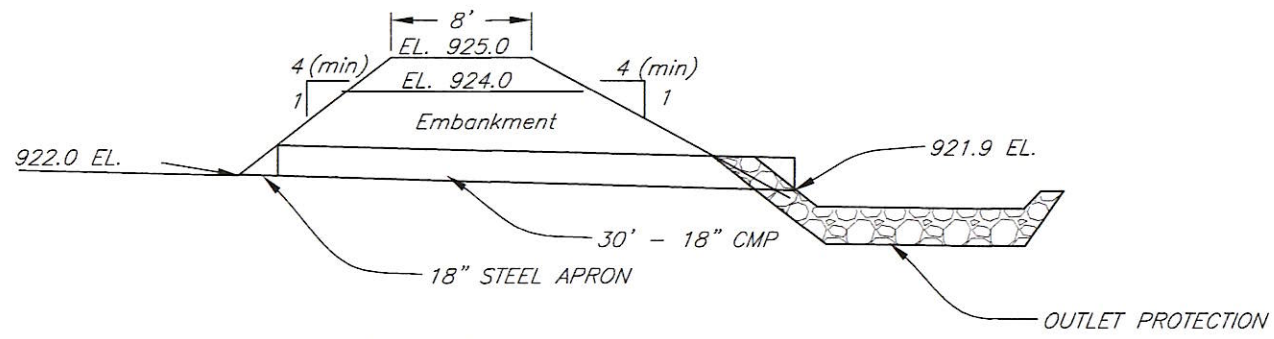

SIDE-WATER INLET PROFILE

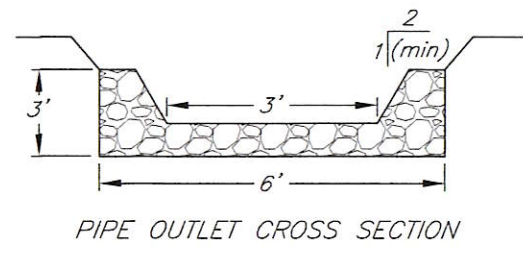

PIPE OUTLET CROSS SECTION

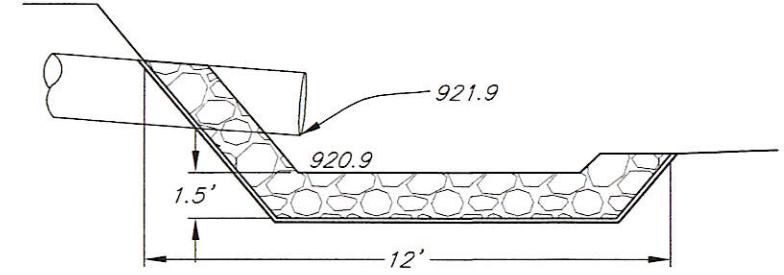

PIPE OUTLET PROFILE

OUTLET PROTECTION DETAILS

BURNHAM CREEK RUSSIA 13 PROJECT
GRADE STABILIZATION

I hereby certify that this plan, specification, or report was prepared by me or under my direct supervision and that I am a duly Licensed Professional Engineer under the laws of the State of Minnesota. JAMES NEST Signature: <i>[Signature]</i> Date: <i>4/12/19</i> Reg. No. 24511	SIDE-WATER INLET
	West Polk Soil & Water Conservation District Polk County, Minnesota
	PREPARED BY RED RIVER VALLEY CONSERVATION SERVICE AREA P.O. BOX 16 GRYGLA, MINNESOTA 56727 (218) 294-6142 Drawn by JAH Checked by JAH Date 04-02-19 Sheet 6 of 6

INSPECTION PLAN
GRADE STABILIZATION
for
Burnham Creek Russia 13 Project

A. GENERAL

The work to be accomplished on this project consists of:

1. common excavation
2. placing of geotextile
3. placing of rock riprap
4. seeding, fertilizing and mulching

B. ITEMS OF WORK TO BE INSPECTED

Common Excavation

Periodic inspection will be required for site preparation.

Geotextile

Periodic inspection will be required for the placement of the materials. Materials delivered to the site need to be inspected and evaluated prior to placement for conformance to specifications. Inspection is needed for proper and uniform placement.

Rock Riprap

Continuous inspection and periodic inspection will be required for the placement of the materials. Materials delivered to the site need to be inspected and evaluated prior to placement for conformance to specifications. Periodic inspection will be required for placement of rock riprap chute.

Seeding, Fertilizing and Mulching

Periodic inspection will be required.

C. PERSONNEL

Someone from the RRVCSA staff or West Polk SWCD staff will be responsible for construction inspection.

Prepared and recommended by:



James Hest, P.E.
Red River Valley Conservation Service Area

Date 4/2/19

RED RIVER VALLEY
CONSERVATION SERVICE AREA

CONSTRUCTION SPECIFICATIONS

FOR

BURNHAM CREEK RUSSIA 13 PROJECT

GRADE STABILIZATION STRUCTURE

SEC 13 T 148 N R 46 W

RUSSIA TOWNSHIP

WEST POLK SOIL AND
WATER CONSERVATION DISTRICT

Burnham Creek Russia 13 Project

Grade Stabilization Project

SPECIFICATIONS

Minnesota Construction Specifications

MN-5	Pollution Control
MN-6	Seeding, Sprigging, and Mulching
MN-21	Excavation
MN-23	Earthfill
MN-26	Topsoiling
MN-51	Corrugated Metal Pipe
MN-61	Rock Riprap
MN-95	Geotextile

Minnesota Material Specifications

MN-523	Rock for Riprap
MN-551	Coated Corrugated Steel Pipe
MN-592	Geotextile

I hereby certify that this plan, specification, or report was prepared by me or under my direct supervision and that I am a duly Registered Professional Engineer under the laws of the State of Minnesota.

JAMES HEST



Signature

Date: 4/2/19

Registration No. 24511

Minnesota Construction Specification 5—Pollution Control

1. Scope

The work consists of installing measures or performing work to control erosion and minimize the production of sediment and other pollutants to water and air from construction activities.

2. Material specification

All material furnished shall meet the requirements of the material specifications listed in section 7 of this specification.

3. Erosion and sediment control measures and works

The measures and works shall include, but are not limited to, the following:

Staging of earthwork activities—The excavation and moving of soil materials shall be scheduled to minimize the size of areas disturbed and unprotected from erosion for the shortest reasonable time.

Seeding—Seeding to protect disturbed areas shall occur as soon as reasonably possible following completion of that earthwork activity.

Mulching—Mulching to provide temporary protection of the soil surface from erosion.

Diversions—Diversions to divert water from work areas and to collect water from work areas for treatment and safe disposition. They are temporary and shall be removed and the area restored to its near original condition when the diversions are no longer required or when permanent measures are installed.

Stream crossings—Culverts or bridges where equipment must cross streams. They are temporary and shall be removed and the area restored to its near original condition when the crossings are no longer required or when permanent measures are installed.

Sediment basins—Sediment basins collect, settle, and eliminate sediment from eroding areas from impacting properties and streams below the construction site(s). These basins are temporary and shall be removed and the area restored to its original condition when they are no longer required or when permanent measures are installed.

Sediment filters—Straw bale filters or geotextile sediment fences trap sediment from areas of limited runoff. Sediment filters shall be properly anchored to prevent erosion under or around them. These filters are temporary and shall be removed and the area restored to its original condition when they are no longer required or when permanent measures are installed.

Waterways—Waterways for the safe disposal of runoff from fields, diversions, and other structures or measures. These works are temporary and shall be removed and the area restored to its original condition when they are no longer required or when permanent measures are installed.

Other—Additional protection measures as specified in section 7 of this specification or required by Federal, State, or local government.

4. Chemical pollution

RRVCSA
West Polk SWCD
Burnham Creek Russia 13 -- Grade Stabilization

April 2, 2019

MN-05-1

The contractor shall provide watertight tanks or barrels or construct a sump sealed with plastic sheets to dispose of chemical pollutants, such as drained lubricating or transmission fluids, grease, soaps, concrete mixer washwater, or asphalt, produced as a by-product of the construction activities. At the completion of the construction work, sumps shall be removed and the area restored to its original condition as specified in section 7 of this specification. Sump removal shall be conducted without causing pollution.

Sanitary facilities, such as chemical toilets, or septic tanks shall not be located next to live streams, wells, or springs. They shall be located at a distance sufficient to prevent contamination of any water source. At the completion of construction activities, facilities shall be disposed of without causing pollution as specified in section 7 of this specification.

5. Air pollution

The burning of brush or slash and the disposal of other materials shall adhere to state and local regulations.

Fire prevention measures shall be taken to prevent the start or spreading of wildfires that may result from project activities. Firebreaks or guards shall be constructed and maintained at locations shown on the drawings.

All public access or haul roads used by the contractor during construction of the project shall be sprinkled or otherwise treated to fully suppress dust. All dust control methods shall ensure safe construction operations at all times. If chemical dust suppressants are applied, the material shall be a commercially available product specifically designed for dust suppression and the application shall follow manufacturer's requirements and recommendations. A copy of the product data sheet and manufacturer's recommended application procedures shall be provided to the engineer 5 working days before the first application.

6. Maintenance, removal, and restoration

All pollution control measures and temporary works shall be adequately maintained in a functional condition for the duration of the construction period. All temporary measures shall be removed and the site restored to near original condition.

7. Construction details

Locate topsoil or other temporary stockpiles of soil in locations where they will not be subject to erosion from concentrated flow.

When permanent vegetation must be disturbed, limit the area of disturbance to the minimum required for the project.

Seed, or otherwise stabilize, disturbed areas in accordance with Construction Specification 6, Seeding, Sprigging, and Mulching.

Costs for pollution control shall to be incidental to the bid item Excavation.

Minnesota Construction Specification 6—Seeding, Sprigging, and Mulching

1. Scope

The work consists of preparing the area for treatment; furnishing and placing seed, sprigs, mulch, fertilizer, inoculants, lime, and other soil amendments; and anchoring mulch or furnishing and installing erosion control material in designated areas as specified.

2. Material

Seed—All seed shall conform to the current rules and regulations of the state where it is being used and shall be from the latest crop available. It shall meet or exceed the standard for purity and germination listed in section 6.

Seed shall be labeled in accordance with the state laws and the U.S. Department of Agriculture rules and regulations under the Federal Seed Act in effect on the date of invitations for bids. Bag tag figures are evidence of purity and germination. No seed will be accepted with a test date of more than 9 months before the delivery date to the site.

Seed that has become wet, moldy, or otherwise damaged in transit or storage will not be accepted. The percent of noxious weed seed allowable shall be as defined in the current State laws relating to agricultural seeds. Each type of seed shall be delivered in separate sealed containers and fully tagged unless exception is granted in writing by the engineer.

Fertilizer—Unless otherwise specified, the fertilizer shall be a commercial grade fertilizer. It shall meet the standard for grade and quality specified by State law. Where fertilizer is furnished from bulk storage, the contractor shall furnish a supplier's certification of analysis and weight. When required by the contract, a representative sample of the fertilizer shall be furnished to the engineer for chemical analysis.

Inoculants—The inoculant for treating legume seeds shall be a pure culture of nitrogen-fixing bacteria prepared specifically for the species and shall not be used later than the date indicated on the container or as otherwise specified. A mixing medium, as recommended by the manufacturer, shall be used to bond the inoculant to the seed. Two times the amount of the inoculant recommended by the manufacturer shall be used except four times the amount shall be used when seed is applied using a hydraulic seeder. Seed shall be sown within 24 hours of treatment and shall not remain in the hydraulic seeder longer than 4 hours.

Lime and other soil amendments—Lime shall consist of standard ground agriculture limestone, or approved equivalent. Standard ground agriculture limestone is defined as ground limestone meeting current requirements of the State Department of Agriculture. Other soil amendments shall meet quality criteria and application requirements specified in section 6.

Mulch tackifiers—Asphalt emulsion tackifiers shall conform to the requirements of ASTM D 977, Specification for Emulsified Asphalt. The emulsified asphalt may be rapid setting, medium setting, or slow setting. Nonasphaltic tackifiers required because of environmental considerations shall be as specified in section 6.

Straw mulch material—Straw mulch shall consist of wheat, barley, oat or rye straw, hay, grass cut from native grasses, or other plants as specified in section 6. The mulch material shall be air-dry,

reasonably light in color, and shall not be musty, moldy, caked, or otherwise of low quality. The use of mulch that contains noxious weeds is not permitted. The contractor shall provide a method satisfactory to the engineer for determining weight of mulch furnished.

Other erosion control materials—such as wood cellulose fiber mulch, mulch tackifiers, synthetic fiber mulch, netting, and mesh, are other mulching materials that may be required for specialized locations and conditions. These materials, when specified, must be accompanied by the manufacturer's recommendations for methods of application.

3. Seeding mixtures, sod, sprigs, and dates of planting

The application rate per acre for seed mixtures, sprigs, or sod and date of seeding or planting shall be as shown on the plans or as specified in section 6.

4. Seedbed preparation and treatment

Areas to be treated shall be dressed to a smooth, firm surface. On sites where equipment can operate on slopes safely, the seedbed shall be adequately loosened (4 to 6 inches deep) and smoothed. Depending on soil and moisture conditions, disking or cultipacking, or both, may be necessary to properly prepare a seedbed. Where equipment cannot operate safely, the seedbed shall be prepared by hand methods by scarifying to provide a roughened soil surface so that broadcast seed will remain in place.

If seeding is to be accomplished immediately following construction operations, seedbed preparation may not be required except on a compacted, polished, or freshly cut soil surface.

Rocks larger than 6 inches in diameter, trash, weeds, and other debris that will interfere with seeding or maintenance operations shall be removed or disposed of as specified in section 6.

Seedbed preparation shall be discontinued when soil moisture conditions are not suitable for the preparation of a satisfactory seedbed as determined by the engineer.

5. Seeding, sprigging, fertilizing, mulching, and stabilizing

All seeding or sprigging operations shall be performed in such a manner that the seed or sprigs are applied in the specified quantities uniformly in the designated areas. The method and rate of seed application shall be as specified in section 6. Unless otherwise specified, seeding or sprigging shall be accomplished within 2 days after final grading is completed and approved.

Fertilizer, lime, and other soil amendments shall be applied as specified in section 6. When specified, the fertilizer and soil amendments shall be thoroughly incorporated into the soil immediately following surface application.

The rate, amount, and kind of mulching or erosion control material shall be as specified in section 6. Mulches shall be applied uniformly to the designated areas. They shall be applied to areas seeded not later than 2 working days after seeding has been performed. Straw mulch material shall be stabilized within 24 hours of application using a mulch crimper or equivalent anchoring tool or by a suitable tackifier. When the mulch crimper or equivalent anchoring tool is used, it shall have straight blades and be the type manufactured expressly for and capable of firmly punching the mulch into the soil. Where the equipment can be safely operated, it shall be operated on the contour. Hand methods shall be used where equipment cannot safely operate to perform the work required.

The tackifier shall be applied uniformly over the mulch material at the specified rate, or it shall be injected into the mulch material as it is being applied. Mesh or netting stabilizing materials shall be applied smoothly, but loosely on the designated areas. The edges of these materials shall be buried or securely anchored using spikes or staples as specified in section 6.

The Contractor shall maintain the mesh or netting areas until all work under the contract has been completed and accepted. Maintenance shall consist of the repair of areas damaged by water erosion, wind, fire, or other causes. Such areas shall be repaired to reestablish the intended condition and to the design lines and grades required by the contract. The areas shall be refertilized, reseeded, and remulched before the new application of the mesh or netting.

6. Construction details

The seeding mixture shall consist of one of the following:

<u>Seeding Mixture</u>	<u>Lbs/acre</u>
Intermediate Wheatgrass	23
Timothy	7
Canada Wildrye	7

<u>Seeding Mixture</u>	<u>Lbs/acre</u>
Creeping Foxtail	10
Timothy	2
Red Top	2
Perennial Rye	3

Seeding Dates - Spring – April 1 to June 15
 Fall – July 15 to September 1

No seeding will be done from September 1 to November 1. After November 1, a dormant seeding may be done. Dormant seeding will not be made on areas covered with ice or when snow is deeper than 2 inches.

Fertilizing

Recommendations shall be determined by using soil test, if no soil test is available, the following minimum amounts of fertilizer shall be used:

<u>Material</u>	<u>Lbs/acre</u>
Nitrogen (N)	80
Phosphorous (P2O5)	80
Potash	80

Mulch

Mulch shall be applied uniformly to the work area on top and any other areas disturbed during construction at a rate of 3,000-4,000 lbs per acre. Straw mulch material shall be stabilized within 24 hours of application using a mulch crimper or equivalent anchoring tool.

Minnesota Construction Specification 21—*Excavation*

1. Scope

The work shall consist of the excavation required by the drawings and specifications and disposal of the excavated materials.

2. Classification

Excavation will be classified as common excavation or rock excavation in accordance with the following definitions or will be designated as unclassified.

Common excavation shall be defined as the excavation of all materials that can be excavated, transported, and unloaded by the use of heavy ripping equipment and wheel tractor-scrappers with pusher tractors or that can be excavated and dumped into place or loaded onto hauling equipment by means of excavators having a rated capacity of one cubic yard and equipped with attachments (such as shovel, bucket, backhoe, dragline or clam shell) appropriate to the character of the materials and the site conditions.

Rock excavation shall be defined as the excavation of all hard, compacted or cemented materials the accomplishment of which requires blasting or the use of excavators larger than defined for common excavation. The excavation and removal of isolated boulders or rock fragments larger than one cubic yard in volume encountered in materials otherwise conforming to the definition of common excavation shall be classified as rock excavation.

Excavation will be classified according to the above definitions by the Engineer, based on his judgment of the character of the materials and the site conditions.

The presence of isolated boulders or rock fragments larger than one cubic yard in size will not in itself be sufficient cause to change the classification of the surrounding material.

For the purpose of this classification, the following definitions shall apply:

Heavy ripping equipment shall be defined as a rear-mounted, heavy duty, single-tooth, ripping attachment mounted on a tractor having a power rating of 200-300 net horsepower (at the flywheel).

Wheel tractor-scraper shall be defined as a self-loading (not elevating) and unloading scraper having a struck bowl capacity of 12-20 yards.

Pusher tractor shall be defined as a track type tractor having a power rating of 200-300 net horsepower (at the flywheel) equipped with appropriate attachments.

Unclassified Excavation. Items designated as "Unclassified Excavation" shall include all materials encountered regardless of their nature or the manner in which they are removed. When excavation is unclassified, none of the definitions or classifications stated in Section 2 of this specification shall apply.

3. Blasting

The transportation, handling, storage, and use of dynamite and other explosives shall be directed and supervised by a person of proven experience and ability in blasting operations.

Blasting shall be done in such a way as to prevent damage to the work or unnecessary fracturing of the foundation and shall conform to any special requirements in Section 10 of this specification.

4. Use of excavated materials

To the extent they are needed, all suitable materials from the specified excavations shall be used in the construction of required permanent earthfill or rockfill. The suitability of materials for specific purposes will be determined by the Engineer. The Contractor shall not waste or otherwise dispose of suitable excavated materials.

5. Disposal of waste materials

All surplus or unsuitable excavated materials will be designated as waste and shall be disposed of at the locations shown on the drawings or shall be disposed of by the Contractor at sites of his own choosing away from the site of the work.

6. Bracing and shoring

Excavated surfaces too steep to be safe and stable if unsupported shall be supported as necessary to safeguard the work and workmen, to prevent sliding or settling of the adjacent ground, and to avoid damaging existing improvements. The width of the excavation shall be increased if necessary to provide space for sheeting, bracing, shoring, and other supporting installations. The Contractor shall furnish, place and subsequently remove such supporting installations.

7. Structure and trench excavation

Structure or trench excavation shall be completed to the specified elevations and to sufficient length and width to include allowance for forms, bracing and supports, as necessary, before any concrete or earthfill is placed or any piles are driven within the limits of the excavation.

8. Borrow Excavation

When the quantities of suitable materials obtained from specified excavations are insufficient to construct the specified fills, additional materials shall be obtained from the designated borrow areas. The extent and depth of borrow pits within the limits of the designated borrow areas shall be as directed by the Engineer.

Borrow pits shall be excavated and finally dressed in a manner to eliminate steep or unstable side slopes or other hazardous or unsightly conditions.

9. Overexcavation

Excavation in rock beyond the specified lines and grades shall be corrected by filling the resulting voids with portland cement concrete made of materials and mix proportions approved by the Engineer. Concrete that will be exposed to the atmosphere when construction is completed shall contain not less than 6 sacks of cement per cubic yard of concrete. Concrete that will be permanently covered shall contain not less than 4-1/2 sacks of cement per cubic yard. The concrete shall be placed and cured as specified by the Engineer.

Excavation in earth beyond the specified lines and grades shall be corrected by filling the resulting voids with approved compacted earthfill, except that, if the earth is to become the subgrade for riprap, rockfill, sand or gravel bedding, or drainfill, the voids may be filled with material conforming to the specifications for the riprap, rockfill, bedding or drainfill.

The cost of unauthorized excavation and the backfill required to replace unauthorized excavation shall be borne by the Contractor.

10. Construction details

No blasting shall be allowed. Ingress and egress to site shall be as directed by Engineer or Engineer's representative. Waste areas shall be as directed by the Engineer or Engineer's representative or be disposed of by the Contractor at sites of his own choosing away from the site of the work.

Minnesota Construction Specification 23—*Earthfill*

1. Scope

The work consists of the construction of earth embankments, other earthfills, and earth backfills required by the drawings and specifications.

Earthfill is composed of natural earth materials that can be placed and compacted by construction equipment operated in a conventional manner.

Earth backfill is composed of natural earth material placed and compacted in confined spaces or adjacent to structures (including pipes) by hand tamping, manually directed power tampers or vibrating plates, or their equivalent.

2. Material specifications

All fill material shall be obtained from required excavations and designated borrow areas. The selection, blending, routing, and disposition of material in the various fills shall be subject to approval by the engineer.

Fill materials shall contain no frozen soil, sod, brush, roots, or other perishable material. Rock particles larger than the maximum size specified for each type of fill shall be removed prior to compaction of the fill.

The types of material used in the various fills shall be as listed and described in the specifications and drawings.

3. Foundation preparation

Foundations for earthfill shall be stripped to remove vegetation and other unsuitable material or shall be excavated as specified.

Except as otherwise specified, earth foundation surfaces shall be graded to remove surface irregularities and shall be scarified parallel to the axis of the fill or otherwise acceptably scored and loosened to a minimum depth of 2 inches. The moisture content of the loosened material shall be controlled as specified for the earthfill, and the surface material of the foundation shall be compacted and bonded with the first layer of earthfill as specified for subsequent layers of earthfill.

Earth abutment surfaces shall be free of loose, uncompacted earth in excess of 2 inches in depth normal to the slope and shall be at such a moisture content that the earthfill can be compacted against them to produce a good bond between the fill and the abutments.

Rock foundation and abutment surfaces shall be cleared of all loose material by hand or other effective means and shall be free of standing water when fill is placed upon them. Occasional rock outcrops in earth foundations for earthfill, except in dams and other structures designed to restrain the movement of water, shall not require special treatment if they do not interfere with compaction of the foundation and initial layers of the fill or the bond between the foundation and the fill.

Foundation and abutment surfaces shall be no steeper than one horizontal to one vertical unless otherwise specified. Test pits or other cavities shall be filled with compacted earthfill conforming to the specifications for the earthfill to be placed upon the foundation.

4. Placement

RRVCSA
West Polk SWCD
Burnham Creek Russia 13– Grade Stabilization

April 2, 2019

MN23-1

Earthfill shall not be placed until the required excavation and foundation preparation have been completed and the foundation has been inspected and approved by the engineer. Earthfill shall not be placed upon a frozen surface nor shall snow, ice, or frozen material be incorporated in the earthfill matrix.

Earthfill shall be placed in approximately horizontal layers. The thickness of each layer before compaction shall not exceed the maximum thickness specified in section 9 or shown on the drawings. Materials placed by dumping in piles or windrows shall be spread uniformly to not more than the specified thickness before being compacted.

Hand compacted earth backfill shall be placed in layers whose thickness before compaction does not exceed the maximum thickness specified for layers of earth backfill compacted by manually directed power tampers.

Earth backfill shall be placed in a manner that prevents damage to the structures and allows the structures to assume the loads from the earth backfill gradually and uniformly. The height of the earth backfill adjacent to a structure shall be increased at approximately the same rate on all sides of the structure.

Earthfill and earth backfill in dams, levees, and other structures designed to restrain the movement of water shall be placed to meet the following additional requirements:

- (a) The distribution of materials throughout each zone shall be essentially uniform, and the earthfill shall be free from lenses, pockets, streaks, or layers of material differing substantially in texture, moisture content, or gradation from the surrounding material. Zone earthfills shall be constructed concurrently unless otherwise specified.
- (b) If the surface of any layer becomes too hard and smooth for proper bond with the succeeding layer, it shall be scarified parallel to the axis of the fill to a depth of not less than 2 inches before the next layer is placed.
- (c) The top surface of embankments shall be maintained approximately level during construction with two exceptions: A crown or cross-slope of about 2 percent shall be maintained to ensure effective drainage, or as otherwise specified for drainfill or sectional zones.
- (d) Dam embankments shall be constructed in continuous layers from abutment to abutment except where openings to facilitate construction or to allow the passage of streamflow during construction are specifically authorized in the contract.
- (e) Embankments built at different levels as described under (c) or (d) above shall be constructed so that the slope of the bonding surfaces between embankment in place and embankment to be placed is not steeper than 3 feet horizontal to 1 foot vertical. The bonding surface of the embankment in place shall be stripped of all material not meeting the requirements of this specification and shall be scarified, moistened, and recompactd when the new earthfill is placed against it. This ensures a good bond with the new earthfill and obtains the specified moisture content and density at the contact of the in-place and new earthfills.

5. Control of moisture content

During placement and compaction of earthfill and earth backfill, the moisture content of the material being placed shall be maintained within the specified range.

The application of water to the earthfill material shall be accomplished at the borrow areas insofar as practicable. Water may be applied by sprinkling the material after placement on the earthfill, if necessary. Uniform moisture distribution shall be obtained by disking.

Material that is too wet when deposited on the earthfill shall either be removed or be dried to the specified moisture content prior to compaction.

If the top surface of the preceding layer of compacted earthfill or a foundation or abutment surface in the zone of contact with the earthfill becomes too dry to permit suitable bond, it shall either be removed or scarified and moistened by sprinkling to an acceptable moisture content before placement of the next layer of earthfill.

6. Compaction

Earthfill—Earthfill shall be compacted according to the following requirements for the class of compaction specified:

Class A compaction—Each layer of earthfill shall be compacted as necessary to provide the density of the earthfill matrix not less than the minimum density specified in Section 9 or identified on the drawings. The earthfill matrix is defined as the portion of the earthfill material finer than the maximum particle size used in the compaction test method specified.

Class B compaction—Each layer of earthfill shall be compacted to a mass density not less than the minimum density specified.

Class C compaction—Each layer of earthfill shall be compacted by the specified number of passes of the type and weight of roller or other equipment specified or by an approved equivalent method. Each pass shall consist of at least one passage of the roller wheel or drum over the entire surface of the layer.

Earth backfill—Earth backfill adjacent to structures shall be compacted to a density equivalent to that of the surrounding in-place earth material or adjacent required earthfill or earth backfill. Compaction shall be accomplished by hand tamping or manually directed power tampers, plate vibrators, walk-behind, miniature, or self-propelled rollers. Unless otherwise specified heavy equipment including backhoe mounted power tampers or vibrating compactors and manually directed vibrating rollers shall not be operated within 2 feet of any structure. Towed or self-propelled vibrating rollers shall not be operated within 5 feet of any structure. Compaction by means of drop weights operating from a crane or hoist is not permitted.

The passage of heavy equipment will not be allowed:

- Over cast-in-place conduits within 14-days after placement of the concrete
- Over cradled or bedded precast conduits within 7 days after placement of the concrete cradle or bedding
- Over any type of conduit until the backfill has been placed above the top surface of the structure to a height equal to one-half the clear span width of the structure or pipe or 2 feet, whichever is greater, except as may be specified in section 9.

Compacting of earth backfill adjacent to structures shall not be started until the concrete has attained the strength specified in section 9 for this purpose. The strength is determined by compression testing of test cylinders cast by the engineer for this purpose and cured at the work site in the manner specified in ASTM C 31 for determining when a structure may be put into service.

When the required strength of the concrete is not specified as described above, compaction of earth backfill adjacent to structures shall not be started until the following time intervals have elapsed after placement of the concrete.

<u>Structure</u>	Time interval (days)
Vertical or near-vertical walls with earth loading on one side only	14
Walls backfilled on both sides simultaneously	7
Conduits and spillway risers, cast-in-place (with inside forms in place)	7
Conduits and spillway risers, cast-in-place (inside forms removed)	14
Conduits, pre-cast, cradled	2
Conduits, pre-cast, bedded	1
Cantilever outlet bents (backfilled both sides simultaneously)	3

7. Reworking or removal and replacement of defective earthfill

Earthfill placed at densities lower than the specified minimum density or at moisture contents outside the specified acceptable range of moisture content or otherwise not conforming to the requirements of the specifications shall be reworked to meet the requirements or removed and replaced by acceptable earthfill. The replacement earthfill and the foundation, abutment, and earthfill surfaces upon which it is placed shall conform to all requirements of this specification for foundation preparation, approval, placement, moisture control, and compaction.

8. Testing

During the course of the work, the engineer will perform quality assurance tests required to identify material; determine compaction characteristics; determine moisture content; and determine density of earthfill in place. Tests performed by the engineer will be used to verify that the earthfills conform to contract requirements of the specifications. Such tests are not intended to provide the Contractor with the information required by him for the proper execution of the work and their performance shall not relieve the Contractor of the necessity to perform tests for that purpose.

Densities of earthfill requiring Class A compaction will be determined in accordance with ASTM D 1556, D 2167, D 2922, or D 2937 except that the volume and moist weight of included rock particles larger than those used in the compaction test method specified for the type of fill will be determined and deducted from the volume and moist weight of the total sample before computation of density or, if using the nuclear gauge, added to the specified density to bring it to the measure of equivalent composition for comparison (See ASTM D 4718). The density so computed is used to determine the percent compaction of the earthfill matrix. Unless otherwise specified, moisture content is determined by one of the following methods: ASTM D 2216, D 3017, D 4643, D 4944, or D 4959.

9. Construction details

Moisture – "The moisture content of the fill material shall be maintained within the limits required to: (a) prevent bulking or dilatance of the material under the action of the hauling or compacting equipment; (b) prevent the adherence of the fill material to the treads and tracks of the equipment; and (c) insure the crushing and blending of the soil clods and aggregations into a reasonable homogeneous mass."

Compaction - The compaction for earthfill shall be Class C compaction. Each layer of earthfill shall be compacted with 3 passes of a 200 pounds per square inch tamping roller or 3 passes of loaded rubber tire hauling equipment in such a manner that every point on the surface will be traversed by not less than 1 tread track of loaded equipment traveling in a direction parallel to the main axis of the fill.

Earth Backfill adjacent to structures (including pipes) shall be compacted to a density equivalent to that of the surrounding in-place earth materials. Compaction shall be accomplished by means of hand tamping or manually directed power tampers, plate vibrators, walk-behind, miniature, or self-propelled rollers. Unless otherwise specified, heavy equipment including backhoe mounted power tampers, or vibrating compactors and manually directed vibrating rollers, shall not be operated within two (2) feet of any structure.

Earthfill shall have a maximum lift thickness of 9 inches and a maximum rock size of 4 inches. Earth backfill shall have a maximum lift thickness of 4 inches and a maximum rock size of 2.5 inches.

Minnesota Construction Specification 26—Topsoiling

1. Scope

The work consists of furnishing and spreading topsoil on areas disturbed by construction to depths specified in Section 6.

2. Quality of topsoil

Topsoil shall consist of friable surface soil reasonably free of grass, roots, weeds, sticks, rocks, or other unsuitable material. Additional quality requirements, if any, are in section 6 of this specification.

3. Furnishing

Topsoil shall be salvaged from designated earth surfaces that will be disturbed by construction activities. After designated sites have been cleared and grubbed, the topsoil shall be removed from the designated areas and stockpiled at locations shown on the drawings or acceptable to the engineer. Unsuitable material encountered during removal of topsoil shall be disposed of at locations shown on the drawings or approved by the engineer, or it will be otherwise hauled and disposed of at locations removed from the construction site. The contractor is responsible for complying with all local rules and regulations and the payment of any and all fees that may result from the disposal at locations outside the construction work limits.

4. Stockpiling

Stockpiles of topsoil shall not conflict with the requirements of Construction Specification 5, Pollution Control, when made a part of this contract.

5. Spreading

Spreading shall not be performed when the ground or topsoil is frozen, excessively wet, or otherwise in a condition detrimental to uniform spreading operations. Surfaces designated to receive a topsoil application shall be lightly scarified just before the spreading operation. Where compacted earthfills are designated to be topsoiled, the topsoil shall be placed concurrently with the earthfill and shall be bonded to the compacted fill with the compacting equipment.

Following the spreading operation, the topsoil surface shall be left reasonably smooth and without ruts or surface irregularities that could contribute to concentrated waterflow downslope.

6. Construction details

The contractor shall salvage topsoil excavation and/or provide from areas approved by Engineer or Engineer's representative. The topsoil shall be spread to a minimum depth of 4 inches on the excavated areas and other areas as directed by the engineer. The maximum size of rock shall be 2 inches. Costs for topsoiling shall be included in the bid item Excavation.

Minnesota Construction Specification 51—Corrugated Metal Pipe

1. SCOPE

The work shall consist of furnishing and placing circular, arched or elliptical corrugated metal pipe and the necessary fittings.

2. MATERIAL SPECIFICATIONS

Pipe and fittings shall conform to the requirements of Material Specification 551 or Material Specification 552, whichever is specified.

Unless otherwise specified in Section 10 of this specification or as shown on the construction drawings, perforated pipe furnished shall meet the requirements for Class I perforations as described in ASTM A 760 or A 762.

3. COUPLING BANDS AND HARDWARE

Pipe joint coupling bands shall be provided meeting the requirements specified in Section 10 or as shown on the construction drawings.

Hardware consisting of coupling bands and band fastening devices such as connecting bolts, rods, lugs and angles used in conjunction with zinc-coated iron or steel pipe shall be galvanized by the hot-dip method. Hardware used in conjunction with aluminum pipe and aluminum or aluminum-zinc alloy-coated iron and steel pipe shall be of the same material as the pipe except that hot-dip galvanized or cadmium plated fasteners may be used. The surface of all band-fastening devices for pipe specified with bituminous or polymer coating shall be coated with asphalt mastic materials meeting the requirements of ASTM A 849. The coupling band shall be coated similar to that specified for the pipe unless otherwise specified in Section 10 or as shown on the construction drawings.

Coupling bands shall be installed to provide straight alignment of the connecting pipe ends. Unless otherwise specified in Section 10 or as shown on the construction drawings, the band width shall be as specified in ASTM A 760 and A 762. The bands shall be positioned to overlap adjacent pipe ends equally. The coupling bands shall be corrugated to match the corrugations of the connecting pipe ends.

4. FABRICATION

Fabrication of appurtenant sections shall be done as shown on the construction drawings and described in Section 10 of this specification. The items may consist of inlet sections, outlet sections, end sections, elbows, skew or beveled sections, rod reinforced ends, cut-off collars, or headwalls. Fabrication of these appurtenant sections shall be made from metallic-coated materials identical to those from which the attached pipe is fabricated. Fabrication shall be of a quality and finished workmanship equal to that required for the pipe.

5. HANDLING THE PIPE

The Contractor shall furnish equipment as necessary to place the pipe without damaging the pipe or coatings. The pipe shall be transported and handled in a manner to prevent damage to the pipe or coating.

6. LAYING AND BEDDING THE PIPE

Unless otherwise specified, the pipe shall be installed in accordance with the manufacturer's recommendations. The pipe shall be laid with the outside laps of circumferential joints pointing upstream and with longitudinal laps at the sides at about the vertical midheight of the pipe.

Field welding of corrugated galvanized iron or steel pipe will not be permitted. The pipe sections shall be joined with fabricator-supplied coupling bands meeting the specified joint requirements. The coupling shall be made as recommended by the fabricator.

The pipe shall be firmly and uniformly bedded throughout its entire length to the depth and in the manner specified on the drawings.

Perforated pipe shall be laid with the perforations down and oriented symmetrically about a vertical center line. Perforations shall be clear of any obstructions at the time the pipe is laid.

The pipe shall be loaded sufficiently during backfilling around the sides to prevent its being lifted from the bedding.

7. STRUTTING

When required, struts or horizontal ties shall be installed in the manner specified on the drawings. Struts and ties shall remain in place until the backfill has been placed above the top of the pipe to a height of 5 feet or the pipe diameter, whichever is the greater, or has been completed if the finished height is less than 5 feet above the top of the pipe; at which time struts or ties used shall be removed by the Contractor.

8. EMBEDMENT IN CONCRETE

Special treatment shall be provided to pipe embedded in or attached to concrete when the pipe is aluminum or aluminum-coated and aluminum-zinc alloy-coated. Potential contact surfaces shall be insulated. All aluminum, aluminum-coated, and aluminum-zinc alloy-coated pipe surfaces in contact with concrete and masonry surfaces shall be coated with two coats of a bituminous paint of the cut-back type. Placement of the pipe shall be such that direct metal-to-metal contact with other metallic materials, such as embedded steel reinforcement or water control gates, is prevented.

9. REPAIR OF DAMAGED COATINGS

Any damage to the metallic coating shall be repaired by cleaning the damaged surface area by sand blasting, power disk sanding or wire brushing. All loose and cracked coating, dirt, and any products of corrosion shall be removed prior to application of two (2) coats of paint. Oil and grease materials shall be removed by use of a solvent. The surface shall be clean and dry during the painting period and until the coating has dried.

Painting shall be by use of one of the following options based upon installed exposure of the pipe as determined by the Engineer:

Normal exterior or interior atmospheric exposure:

- a. Zinc dust - zinc oxide primer, Federal Specification TT-P-641, Type I or Type II, or
- b. Single-package, moisture-cured urethane primer in silver metallic color, or
- c. Zinc-rich cold galvanizing compound, brush, or aerosol application.

Submergence in water exposure:

- a. Zinc dust - zinc oxide primer, ASTM D 79 and D 520
- b. Zinc dust paint, ASTM D 4146

If the metallic coating is damaged in any individual area larger than 12 square inches, or if more than 0.2 percent of a total surface area of a length of pipe is damaged, the length will be rejected.

Breaks or scuffs in bituminous coatings that are less than 36 square inches in area shall be repaired by the application of two coats of hot asphaltic paint or a coating of cold-applied bituminous mastic. The repair coating shall be at least 0.05 inches thick after hardening and shall bond securely and permanently to the pipe. The material shall meet the physical requirements for bituminous coatings contained in ASTM A 849 and A 885. Whenever individual breaks exceed 36 square inches in area or when the total area of breaks exceeds 0.5 percent of the total surface area of a length of pipe, the pipe length will be rejected.

Bituminous coating damaged by welding of coated pipe or pipefittings shall be repaired as specified in this Section for breaks or scuffs in bituminous coatings.

Breaks or scuffs in polymer coatings that are less than 36 square inches in area shall be repaired by the application of two coats of a polymer material similar to and compatible with the durability, adhesion and appearance of the original polymer coating, not as described in ASTM A 762, paragraph 11.5.1. The repair coating shall be a minimum thickness of 0.010 inches (10 mils) after drying. Whenever individual breaks exceed 36 square inches in area or when the total area of breaks exceeds 0.5 percent of the total surface area of a length of pipe, the pipe length will be rejected.

10. CONSTRUCTION DETAILS

The following flat gasket joining systems have been industry tested and certified by independent laboratories that they meet the leakage requirements of ASTM A 760 Section 9.2.4 [zero leakage for a minimum period of 10 minutes at a minimum pressure of 10 psi (23-ft head)].

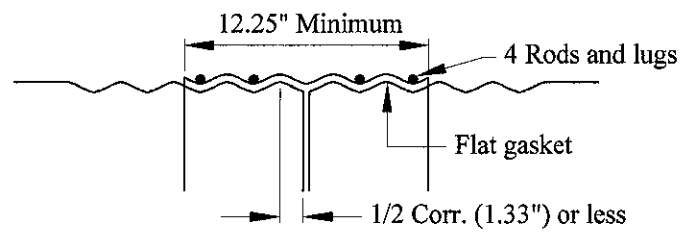

5C CONNECTING BAND WITH 12" WIDE FLAT GASKET
FOR 12" TO 48" DIA. HELICAL PIPE WITH REROLED ENDS

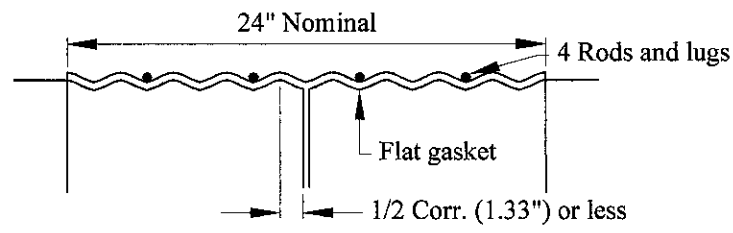

9C CONNECTING BAND WITH 24" WIDE FLAT GASKET
FOR 12" TO 60" DIA. HELICAL PIPE WITH REROLED ENDS

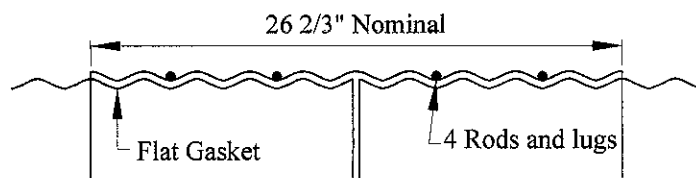

10C CONNECTING BAND WITH 24" WIDE FLAT GASKET
FOR 12" TO 60" DIA. ANNULAR PIPE

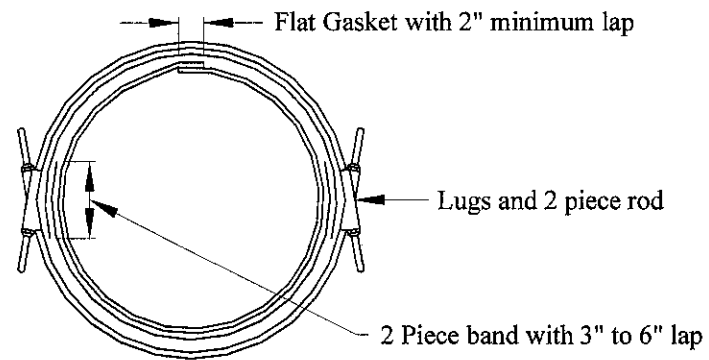

CONNECTING BAND SECTION

PIPE

The corrugated steel pipe shall have 2-2/3" x 1/2" corrugations. The corrugations may be helical with reroled ends and standard lock seams, or annular with close rivets and caulked seams as specified on the drawings. The close rivet details are contained in Material Specification 551.

From ASTM A760, the minimum corrugation depth is 0.44", and the average inside diameter shall not vary more than 1% or 0.5", whichever is greater (11.5" to 12.5" for 12" dia. pipe, and 47.5" to 48.5" for 48" dia. pipe). If the difference in pipe diameters at a joint approaches 1", consult the manufacturer to ensure a leakage resistant joint.

The rerolled ends on helical pipe (inside and outside) shall be painted with 2 coats of paint at the plant in accordance with Section 9 of this specification.

FLAT GASKET and LUBRICANT

Flat gaskets shall be 3/8" thick, closed-cell neoprene in accordance with ASTM D1056, Grade 2C2 or 2C3. Gaskets with adhesive backing shall not be permitted. The width of the gasket shall be one piece. The flat gasket shall be wrapped around the pipe joint, overlapped a minimum of 2", and temporarily secured with tape.

The lubricant shall be pipe joint lubricant compliant with NSF Standard 61. The inside of the connecting bands shall be lubricated before placement over the flat gasket. Apply lubricant evenly and thinly over the entire surface.

CONNECTING BANDS

The flat gasket connecting band diameter shall be approximately 1" larger than the nominal pipe diameter to facilitate band installation over the flat gasket.

The bands shall be two-piece with two 3" to 6" laps.

The band width shall be as specified on the drawings.

The steel band gauge shall be as follows:

<u>Steel Pipe Gauge (thickness)</u>	<u>Steel Band Gauge</u>
16 (0.064")	16
14 (0.079")	16
12 (0.109")	16
10 (0.138")	14

When placing the band under the pipe use caution to avoid getting soil between the band and pipe.

The rods shall be two-piece using 1/2" diameter galvanized steel. The lugs shall be standard tank lugs.

The bands shall be gently tapped with a rubber hammer (or other non-marring method) to ensure an even band seating as the rod nuts are tightened on the lugs.

Minnesota Construction Specification 61—Rock Riprap

1. Scope

The work shall consist of the construction of rock riprap protection, rock riprap chute and rock anchor boulders, including filter or bedding where specified.

2. Material Specifications

Rock riprap shall conform to the requirements of Material Specification MN-523, Rock for Riprap, or if so specified, shall be obtained from designated sources. It shall be free from dirt, clay, sand, rock fines, and other material not meeting the required gradation limits.

At least 30 days before rock is delivered from other than designated sources, the contractor shall designate in writing the source from which rock material will be obtained and provide information satisfactory to the Engineer that the material meets contract requirements. The Contractor shall provide the Engineer free access to the source for the purpose of obtaining samples for testing. The size and grading of the rock shall be as specified in section 7 or on the drawings.

Rock from approved sources shall be excavated, selected, and processed to meet the specified quality and grading requirements at the time the rock is installed.

Filter or bedding aggregates when required shall conform to Material Specification 521, Aggregates for Drainfill and Filters, unless otherwise specified. Geotextiles shall conform to Material Specification 592, Geotextile.

3. Subgrade preparation

The subgrade surface on which the rock riprap, filter, bedding, or geotextile is to be placed shall be cut or filled and graded to the lines and grades shown on the drawings. When fill to subgrade lines is required, it shall consist of approved material and shall conform to the requirements of the specified class of earthfill.

Rock riprap, filter, bedding, or geotextile shall not be placed until the foundation preparation is complete and the subgrade surface has been inspected and approved.

4. Equipment-placed rock riprap

The rock riprap shall be placed by equipment on the surface and to the depth specified. It shall be installed to the full course thickness in one operation and in such a manner as to avoid serious displacement of the underlying material. The rock for riprap shall be delivered and placed in a manner that ensures the riprap in place is reasonably homogeneous with the larger rocks uniformly distributed and firmly in contact one to another with the smaller rocks and spalls filling the voids between the larger rocks. Some hand placing may be required to provide a neat and uniform surface.

Rock riprap shall be placed in a manner to prevent damage to structures. Hand placing is required as necessary to prevent damage to any new and existing structures.

5. Hand placed rock riprap

The rock riprap shall be placed by hand on the surface and to the depth specified. It shall be securely bedded with the larger rocks firmly in contact one to another without bridging. Spaces between the larger rocks shall be filled with smaller rocks and spalls. Smaller rocks shall not be grouped as a substitute for larger rock. Flat slab rock shall be laid on its vertical edge except where it is laid like paving stone and the thickness of the rock equals the specified depth of the riprap course.

6. Filter or bedding

When the contract specifies filter, bedding, or geotextile beneath the rock riprap, the designated material shall be placed as specified. Compaction of filter or bedding aggregate is not required, but the surface of such material shall be finished reasonably smooth and free of mounds, dips, or windrows.

7. Construction details

The contractor shall supply and place the rock riprap as shown on the drawings. Geotextile shall be used beneath the rock riprap.

The rock riprap shall be sized as follows:

MNDOT Standard Specification 3601 Class III for rock riprap chute and rock riprap protection.

The rock riprap shall be placed by equipment in such a manner as not to damage the underlying geotextile.

Minnesota Construction Specification 95—Geotextile

1. Scope

This work consists of furnishing all material, equipment, and labor necessary for the installation of geotextiles.

2. Quality

Geotextiles shall conform to the requirements of Material Specification 592 and this specification.

3. Storage

Before use, the geotextile shall be stored in a clean, dry location out of direct sunlight, not subject to extremes of either hot or cold temperatures, and with the manufacturer's protective cover undisturbed. Receiving, storage, and handling at the job site shall be in accordance with the requirements listed in ASTM D 4873.

4. Surface preparation

The surface on which the geotextile is to be placed shall be graded to the neat lines and grades as shown on the drawings. It shall be reasonably smooth and free of loose rock and clods, holes, depressions, projections, muddy conditions, and standing or flowing water (unless otherwise specified in section 6 of this specification).

5. Placement

Before the geotextile is placed, the soil surface will be reviewed for quality assurance of the design and construction. The geotextile shall be placed on the approved prepared surface at the locations and in accordance with the details shown on the drawings and specified in section 6 of this specification. It shall be unrolled along the placement area and loosely laid, without stretching, in such a manner that it conforms to the surface irregularities when material or gabions are placed on or against it. The geotextile may be folded and overlapped to permit proper placement in designated area(s).

Method 1—The geotextile shall be joined by machine sewing using thread material meeting the chemical requirements for the geotextile fibers or yarn. The sewn overlap shall be 6 inches, and the sewing shall consist of two parallel stitched rows at a spacing of about 1 inch and shall not cross (except for any required re-stitching). The stitching shall be a lock-type stitch. Each row of stitching shall be located a minimum of 2 inches from the geotextile edge. The seam type and sewing machine to be used shall produce a seam strength, in the specified geotextile, that provides a minimum of 90 percent of the tensile strength in the weakest principal direction of the geotextile being used, when tested in accordance with ASTM D 4884. The seams may be factory or field sewn.

The geotextile shall be temporarily secured during placement of overlying material to prevent slippage, folding, wrinkling, or other displacement of the geotextile. Unless otherwise specified, methods of securing shall not cause punctures, tears, or other openings to be formed in the geotextile.

Method 2—The geotextile shall be joined by overlapping a minimum of 18 inches (unless otherwise specified) and secured against the underlying foundation material. Securing pins, approved and provided by the geotextile manufacturer, shall be placed along the edge of the panel or roll material to adequately hold it in place during installation. Pins shall be steel or fiberglass formed as a U, L, or T shape or contain "ears" to prevent total penetration through the geotextile. Steel washers shall be provided on all but the U-shaped pins. The upstream or upslope geotextile shall overlap the abutting

RRVCSA

April 2, 2019

MN-95-1

West Polk SWCD

Burnham Creek Russia 13 - Grade Stabilization

downslope geotextile. At vertical laps, securing pins shall be inserted through the bottom layers along a line through approximately the mid-point of the overlap. At horizontal laps and across slope laps, securing shall be inserted through the bottom layer only. Securing pins shall be placed along a line about 2 inches in from the edge of the placed geotextile at intervals not to exceed 12 feet unless otherwise specified. Additional pins shall be installed as necessary and where appropriate to prevent any undue slippage or movement of the geotextile. The use of securing pins will be held to the minimum necessary. Pins are to remain in place unless otherwise specified.

Should the geotextile be torn or punctured, or the overlaps or sewn joint disturbed, as evidenced by visible geotextile damage, subgrade pumping, intrusion, or grade distortion, the backfill around the damaged or displaced area shall be removed and restored to the original approved condition. The repair shall consist of a patch of the same type of geotextile being used and overlaying the existing geotextile. When the geotextile seams are required to be sewn, the overlay patch shall extend a minimum of 1 foot beyond the edge of any damaged area and joined by sewing as required for the original geotextile except that the sewing shall be a minimum of 6 inches from the edge of the damaged geotextile. Geotextile panels joined by overlap shall have the patch extend a minimum of 2 feet from the edge of any damaged area.

Geotextile shall be placed in accordance with the following applicable specification according to the use indicated in section 6:

Slope protection—The geotextile shall not be placed until it can be anchored and protected with the specified covering within 48 hours or protected from exposure to ultraviolet light. In no case shall material be dropped on uncovered geotextile from a height of more than 3 feet.

Subsurface drains—The geotextile shall not be placed until drainfill or other material can be used to provide cover within the same working day. Drainfill material shall be placed in a manner that prevents damage to the geotextile. In no case shall material be dropped on uncovered geotextile from a height of more than 5 feet.

Road stabilization—The geotextile shall be unrolled in a direction parallel to the roadway centerline in a loose manner permitting conformation to the surface irregularities when the roadway fill material is placed on its surface. In no case shall material be dropped on uncovered geotextile from a height of more than 5 feet. Unless otherwise specified, the minimum overlap of geotextile panels joined without sewing shall be 24 inches. The geotextile may be temporarily secured with pins recommended or provided by the manufacturer, but they shall be removed before the permanent covering material is placed.

6. Construction details

The geotextile shall be placed as slope protection as shown on the drawings. It shall meet the property requirements of a class 1 non-woven geotextile and be installed using Method 2 indicated in section 5.

Costs for geotextile shall be incidental to the bid item Rock Riprap.

Material Specification 523—Rock for Riprap

1. Scope

This specification covers the quality of rock to be used in the construction of rock riprap.

2. Quality

Individual rock fragments shall be dense, sound, and free from cracks, seams, and other defects conducive to accelerated weathering. Except as otherwise specified, the rock fragments shall be angular to subrounded. The least dimension of an individual rock fragment shall be not less than one-third the greatest dimension of the fragment. ASTM D 4992 provides guidance on selecting rock from a source.

Except as otherwise provided, the rock shall be tested and shall have the following properties:

Rock type 1

- **Bulk specific gravity (saturated surface-dry basis)**—Not less than 2.5 when tested in accordance with ASTM C 127 on samples prepared as described for soundness testing.
- **Absorption**—Not more than 2 percent when tested in accordance with ASTM C 127 on samples prepared as described for soundness testing.
- **Soundness**—The weight loss in 5 cycles shall not be more than 10 percent when sodium sulfate is used or more than 15 percent when magnesium sulfate is used.

Rock type 2

- **Bulk specific gravity (saturated surface-dry basis)**—Not less than 2.5 when tested in accordance with ASTM C 127 on samples prepared as described for soundness testing.
- **Absorption**—Not more than 2 percent when tested in accordance with ASTM C 127 on samples prepared as described for soundness testing.
- **Soundness**—The weight loss in 5 cycles shall be not more than 20 percent when sodium sulfate is used or more than 25 percent when magnesium sulfate is used.

Rock type 3

- **Bulk specific gravity (saturated surface-dry basis)**—Not less than 2.3 when tested in accordance with ASTM C 127 on samples prepared as described for soundness testing.
- **Absorption**—Not more than 4 percent when tested in accordance with ASTM C 127 on samples prepared as described for soundness testing.
- **Soundness**—The weight loss in 5 cycles shall be not more than 20 percent when sodium sulfate is used or more than 25 percent when magnesium sulfate is used.

3. Methods of soundness testing

Rock cube soundness—The sodium or magnesium sulfate soundness test for all rock types (1, 2, or 3) shall be performed on a test sample of $5,000 \pm 300$ grams of rock fragments, reasonably uniform in size and cubical in shape, and weighing, after sampling, about 100 grams each. They shall be obtained from rock samples that are representative of the total rock mass, as noted in ASTM D 4992, and that have been sawed into slabs as described in ASTM D 5121. The samples shall further be reduced in size by sawing the slabs into cubical blocks. The thickness of the slabs and the size of the sawed fragments shall be determined by the size of the available test apparatus and as necessary to provide, after sawing, the approximate 100-gram samples. The cubes shall undergo five cycles of soundness testing in accordance with ASTM C 88.

Internal defects may cause some of the cubes to break during the sawing process or during the initial soaking period. Do not test any of the cubes that break during this preparatory process. Such breakage, including an approximation of the percentage of cubes that break, shall be noted in the test report.

After the sample has been dried following completion of the final test cycle and washed to remove the sodium sulfate or magnesium sulfate, the loss of weight shall be determined by subtracting from the

original weight of the sample the final weight of all fragments that have not broken into three or more fragments.

The test report shall show the percentage loss of the weight and the results of the qualitative examination.

Rock slab soundness—When specified, the rock shall also be tested in accordance with ASTM D 5240. Deterioration of more than 25 percent of the number of blocks shall be cause for rejection of rock from this source. Rock shall also meet the requirements for average percent weight loss stated below.

- For projects located north of the Number 20 Freeze-Thaw Severity Index Isoline (fig. 523-1). Unless otherwise specified, the average percent weight loss for Rock Type 1 shall not exceed 20 percent when sodium sulfate is used or 25 percent when magnesium sulfate is used. For Rock Types 2 and 3, the average percent weight loss shall not exceed 25 percent for sodium sulfate soundness or 30 percent for magnesium sulfate soundness.
- For projects located south of the Number 20 Freeze-Thaw Severity Index Isoline, unless otherwise specified, the average percent weight loss for Rock Type 1 shall not exceed 30 percent when sodium sulfate is used or 38 percent when magnesium sulfate is used. For Rock Types 2 and 3, the average percent weight loss shall not exceed 38 percent for

sodium sulfate soundness or 45 percent for magnesium sulfate soundness.

4. Field durability inspection

Rock that fails to meet the material requirements stated above (if specified), may be accepted only if similar rock from the same source has been demonstrated to be sound after 5 years or more of service under conditions of weather, wetting and drying, and erosive forces similar to those anticipated for the rock to be installed under this specification.

A rock source may be rejected if the rock from that source deteriorates in 3 to 5 years under similar use and exposure conditions expected for the rock to be installed under this specification, even though it meets the testing requirements stated above.

Deterioration is defined as the loss of more than one-quarter of the original rock volume, or severe cracking that would cause a block to split. Measurements of deterioration are taken from linear or surface area particle counts to determine the percentage of deteriorated blocks. Deterioration of more than 25 percent of the pieces shall be cause for rejection of rock from the source.

5. Grading

The rock shall conform to the specified grading limits after it has been placed within the matrix of the rock riprap. Grading tests shall be performed, as necessary, according to ASTM D 5519, Method A, B, or C, as applicable.

Figure 523-1 Number 20 freeze-thaw severity index isoline (map approximates the map in ASTM D 5312)



Material Specification 551—Coated Corrugated Steel Pipe

1. Scope

This specification covers the quality of zinc-coated, aluminum-coated, aluminum-zinc alloy-coated, and polymer-coated corrugated steel pipe and fittings.

2. Pipe

All pipe shall be metallic zinc-coated, aluminum-coated, or aluminum-zinc alloy-coated corrugated steel pipe and fittings conforming to the requirements of ASTM A 742, A 760, A 761, A 762, A 849, A 875, A 885, and A 929 for the specified type, class, fabrication of pipe and coating, and to the following additional requirements:

a. When closed riveted pipe is specified:

- (1) Pipe shall be fabricated with circumferential seam rivet spacing that does not exceed 3 inches except that 12 rivets are sufficient to secure the circumferential seams in 12-inch pipe.
- (2) Longitudinal seams that will be within the coverage area of a coupling band, the rivets shall have flat heads or the rivets and holes shall be omitted and the seams shall be connected by welding to provide a minimum of obstruction to the seating of the coupling bands.

b. Double riveting or double spot welding for pipe less than 42 inches in diameter may be required. When double riveting or double spot welding is specified, the riveting or welding shall be performed in a manner specified for pipe 42 inches or greater in diameter.

3. Coatings

Coatings described herein, unless otherwise specified, equally refer to the inside and outside pipe surfaces.

When coatings in addition to metallic coatings are specified, they shall conform to the requirements of ASTM A 742, A 760, A 761, A 762, A 849, A 875, A 885, and A 929 for the specified type.

Polymer-coated pipe, unless otherwise specified on the drawings or in the construction specifications, shall be coated on each side with a minimum thickness of 0.01 inches (10 mils), designated as grade 10/10 in ASTM A 762.

4. Coupling bands

Coupling bands are to be provided for each section of pipe. The hardware for fastening the coupling band tightly to the connecting pipe shall be fabricated to permit tightening sufficiently to provide the required joint tensile strength and, if required, watertightness without failure of its fastening.

Gaskets, if specified, are to be provided for each coupling band. The fabrication of coupling bands and fastening hardware, in addition to the above, shall be sufficient to provide the required gasket seating without warping, twisting, or bending.

5. Fittings

Fittings shall be fabricated from steel conforming to ASTM A 742, A 849, A 875, A 885, and A 929. The coating of fittings shall be the same as that specified for the contiguous corrugated coated pipe.

Welded surfaces and adjacent surfaces damaged during welding shall be treated by removing all flux residue and weld splatter. The affected surfaces shall be cleaned to bright metal by sand blasting, power disk sanding, or wire brushing. The cleaned area shall extend at least 0.5 inch into the undamaged section of the coated area. Repair and coating application of damaged and uncoated pipe surface areas shall be in accordance with ASTM A 780.

Material Specification 592—Geotextile

1. Scope

This specification covers the quality of geotextiles.

2. General requirements

Fibers (threads and yarns) used in the manufacture of geotextile shall consist of synthetic polymers composed of a minimum of 85 percent by weight polypropylenes, polyesters, polyamides, polyethylene, polyolefins, or polyvinylidene-chlorides. They shall be formed into a stable network of filaments or yarns retaining dimensional stability relative to each other. The geo-textile shall be free of defects and conform to the physical requirements in tables 592-1 and 592-2. The geotextile shall be free of any chemical treatment or coating that significantly reduces its porosity. Fibers shall contain stabilizers and/or inhibitors to enhance resistance to ultraviolet light.

Thread used for factory or field sewing shall be of contrasting color to the fabric and made of high strength polypropylene, polyester, or polyamide thread. Thread shall be as resistant to ultraviolet light as the geotextile being sewn.

3. Classification

Geotextiles shall be classified based on the method used to place the threads or yarns forming the fabric. The geotextiles will be grouped into woven and nonwoven types.

Woven—Fabrics formed by the uniform and regular interweaving of the threads or yarns in two directions. Woven fabrics shall be manufactured from monofilament yarn formed into a uniform pattern with distinct and measurable openings, retaining their position relative to each other. The edges of fabric shall be selvaged or otherwise finished to prevent the outer yarn from unraveling.

Nonwoven—Fabrics formed by a random placement of threads in a mat and bonded by heat-bonding, resin-bonding, or needle punching. Nonwoven fabrics shall be manufactured from individual fibers formed into a random pattern with distinct, but variable small openings, retaining their position

RRVCSA
West Polk SWCD
Burnham Creek Russia 13 – Grade Stabilization

relative to each other when bonded by needle punching, heat, or resin bonding. The use of nonwovens other than the needle punched geotextiles is somewhat restricted (see note 3 of table 592-2).

4. Sampling and testing

The geotextile shall meet the specified requirements (table 592-1 or 592-2) for the product style shown on the label. Product properties as listed in the latest edition of the "Specifiers Guide," Geotechnical Fabrics Report, (Industrial Fabrics Association International, 1801 County Road BW, Roseville, MN 55113-4061) and that represent minimum average roll values, are acceptable documentation that the product style meets the requirements of these specifications.

For products that do not appear in the above directory or do not have minimum average roll values listed, typical test data from the identified production run of the geotextile will be required for each of the specified tests (tables 592-1 or 592-2) as covered under clause AGAR 452.236-76.

5. Shipping and storage

The geotextile shall be shipped/transported in rolls wrapped with a cover for protection from moisture, dust, dirt, debris, and ultraviolet light. The cover shall be maintained undisturbed to the maximum extend possible before placement.

Each roll of geotextile shall be labeled or tagged to clearly identify the brand, class, and the individual production run in accordance with ASTM D 4873.

April 2, 2019

MN-592-1

Table 592-1 Requirements for woven geotextiles

Property	Test method	Class I	Class II & III	Class IV
Tensile strength (pounds) ^{1/}	ASTMD 4632 grab test	200 minimum in any principal direction	120 minimum in any principal direction	180 minimum in any principal direction
Elongation at failure (percent) ^{1/}	ASTMD 4632 grab test	<50	<50	<50
Puncture (pounds) ^{1/}	ASTMD 4833	90 minimum	60 minimum	60 minimum
Ultraviolet light (% residual tensile strength)	ASTMD 4355 150-hr exposure	70 minimum	70 minimum	70 minimum
Apparent opening size (AOS)	ASTMD 4751	As specified, but no smaller than 0.212 mm (#70) ^{2/}	As specified, but no smaller than 0.212 mm (#70) ^{2/}	As specified, but no smaller than 0.212 mm (#70) ^{2/}
Percent open area (percent)	CWO-02215-86	4.0 minimum	4.0 minimum	1.0 minimum
Permittivity sec ⁻¹	ASTMD 4491	0.10 minimum	0.10 minimum	0.10 minimum

1/ Minimum average roll value (weakest principal direction).

2/ U.S. standard sieve size.

Note: CWO is a USACE reference.

Table 592-2 Requirements for nonwoven geotextiles

Property	Test method	Class I	Class II	Class III	Class IV ^{3/}
Tensile strength (lb) ^{1/}	ASTMD 4632 grab test	180 minimum	120 minimum	90 minimum	115 minimum
Elongation at failure (%) ^{1/}	ASTMD 4632	≥ 50	≥ 50	≥ 50	≥ 50
Puncture (pounds)	ASTMD 4833	80 minimum	60 minimum	40 minimum	40 minimum
Ultraviolet light (% residual tensile strength)	ASTMD 4355 150-hr exposure	70 minimum	70 minimum	70 minimum	70 minimum
Apparent opening size (AOS)	ASTMD 4751	As specified max. #40 ^{2/}	As specified max. #40 ^{2/}	As specified max. #40 ^{2/}	As specified max. #40 ^{2/}
Permittivity sec ⁻¹	ASTMD 4491	0.70 minimum	0.70 minimum	0.70 minimum	0.10 minimum

1/ Minimum average roll value (weakest principal direction).

2/ U.S. standard sieve size.

3/ Heat-bonded or resin-bonded geotextile may be used for classes III and IV. They are particularly well suited to class IV. Needle-punched geotextiles are required for all other classes.

May 22, 2019

Myron Jesme

Red Lake Watershed District

1000 Pennington Avenue South

Thief River Falls, MN 56701

Subject: Aquatic Resources Delineation
Drain discharge location at Grand Marais Creek
Esther Township, Polk County, Minnesota

We appreciate the opportunity to provide this proposal for aquatic resources delineation services for the above referenced project, located at Lat. 48.033268 Long. -97.021629. The delineation work will be conducted in accordance with the Great Plains Regional Supplement to the 1987 US Army Corp of Engineers Wetland Delineation Manual. An offsite wetland delineation will be conducted as standard preparation, followed by a full field delineation to map resource presence, locations, and connections to regulated waters. Wetland and other aquatic resource boundaries and sample points will be recorded with a professional GPS unit. Report documents will be provided in electronic form, with hard copies if requested, along with the shapefiles of wetland boundaries and sample point locations.

Scope of Services:

1. Conduct a field delineation to identify the existence and boundaries of wetlands at the site (Figure 1 – delineation assessment area). Wetland boundaries and sample points will be recorded with a professional GPS unit.
2. Provide a field Aquatic Resources Delineation Report for the project characterizing the soils, hydrology, and vegetation for the wetland areas within the project boundaries. The report will identify the Cowardin wetland type and the wetland plant species. The report will also include copies of data forms used for the delineation.
3. Conduct an analysis of the drainage patterns and connectivity of the wetlands at the subject property to any nearby jurisdictional waters. Provide an opinion on the jurisdictional status of the wetlands within the subject property.

Items provided by the client:

1. Access to the property and permission to sample and identify the soils and vegetation contained within the project area.
2. Scheduling flexibility in order to avoid inclement weather conditions that would prohibit completion of the fieldwork.
3. Project Plans showing the proposed project boundaries or boundaries marked in the field with lath prior the fieldwork.

Deliverables for this project:

1. Electronic copy of the Aquatic Resources Delineation Report.
2. Copies of other reports, any permitting correspondence, and other documents identified in the scope of services.
3. The shapefiles of the wetland boundaries, sample points, and other relevant features in a GIS digital format.

Estimated Compensation:

Houston Engineering will provide professional wetland delineation services and complete this Scope of Services, in accordance with the enclosed terms and conditions, for the estimated fee plus reimbursable expenses.

The following is a time and materials estimate of cost proposal pertaining to this project.

Field Delineation and Report	\$ 4,100
Total Time and Materials Quote	\$ 4,100

Thank you for the opportunity to provide this proposal. We look forward to working with you on this project. Should you have any questions, please call me or Mark D. Aanenson at (701) 237-5065 (office).

Sincerely,

HOUSTON ENGINEERING, INC.



Donna Jacob, PhD, PWS, CWD

DJ

Enclosures: Mark D. Aanenson, Tony Nordby, HEI

H:\Fargo\Dept\Environmental\Proposal Development\2019 Proposal development\West Polk County LGU drain into Grand Marais\Wetland delineation scope of service 2019-05-22.docx



Figure 1 - delineation assessment area (yellow outline).



Permit # 18-148

Status Report: **Approved**

Applicant Information

Name	Organization	Address	Email	Phone Number(s)
Ray Kvalvog		323 48th Avenue SW Moorhead, MN 56560		tel:701-793-0188 mobile: fax:

General Information

(1) The proposed project is a:

Surface Drainage (New Ditch or Improvement)

(2) Legal Description

(3) County: **Red Lake** Township: **Poplar River** Range: **42** Section: **35 1/4: NE1/4, SE1/4**

(4) Describe in detail the work to be performed. **Clean 1/2 mile west side of 130th of township road ditch into ditch on County Road 7.**

(5) Why is this work necessary? Explain water related issue/problem being solved. **Improved drainage.**

Status

Status	Notes	Date
Approved	None	May 23, 2019
Tabled	None	Nov. 27, 2018
Received	None	Oct. 22, 2018

Conditions

P.A. #18148 – Previously Tabled at 11-27-2018 Brd. Mtg. Red Lake Watershed District (RLWD) approval to clean the west ditch of township road, and south ditch of Red Lake Co. Hwy. #7, and to remove existing field entrance culverts (2 – 24 in. csp at sta. 46+30) and install one line of 42 in. dia. csp; as per approval of Poplar River Township and Red Lake Co. Hwy. Dept. specs/conditions; proposed work is within township road Right-of Way and Co. Hwy. #7 Right-of Way. All excavation shall be consistent with the existing road and ditch slopes and there shall be no vertical excavation faces. All excavation shall be laser controlled and furnished by the contractor. Contact persons at Red Lake Co. Hwy. Dept. are Engineer Eric Hove or Randy Konickson at 218-253-2697 The RLWD has performed an elevation survey of the ditch bottoms, and existing culverts. A copy of the survey will be provided to the applicant with the proposed ditch grade for excavation. Note: Total flow from the existing drain/coulee shall not be routed in the proposed ditch excavation. Flows from high runoff events, shall be allowed to pass downstream (Northwest) in the existing drain. Elevation of the 'overflow' will be determined by the Red Lake Watershed District prior to excavation. Prior to any work, applicant shall contact Red Lake Electric Cooperative concerning the overhead power lines and power poles along the township road portion of the proposed work. Contact person at Red Lake Electric is Steve Conely at 218-253-2168 or 218-689-3041. For proposed work on lands not owned by applicant, he/she must obtain, in writing, permission from the affected landowners to perform proposed work. Applicant is responsible for utility locates by calling Gopher 1. (1-800-252-1166)

P.A. #18148 – “Table” @ 11-27-2018 mtg. I recommend this permit be “tabled” until after the 2019 Spring melt. This will allow for adequate time to observe runoff conditions, water elevations, and existing flow patterns and possible split flows. The Red Lake Watershed District (RLWD) has performed an elevation survey which is currently in review.

NOTE: This permit does not relieve the applicant of any requirements for other permits which may be necessary from Township, County, State, or Federal Government Agencies.



Permit # 18-156

Status Report: **Approved**

Applicant Information

Name	Organization	Address	Email	Phone Number(s)
Brent Strand		3542 6th Street East West Fargo, ND 58078		tel: mobile: 218-686-7886 fax:

General Information

(1) The proposed project is a:

Culvert Installation / Removal / Modification

(2) Legal Description

(3) County: **Red Lake** Township: **Poplar River** Range: **42** Section: **26 1/4: NW1/4**

(4) Describe in detail the work to be performed. **Replace existing 36"x20' culvert with a 36"x30' culvert in field approach.**

(5) Why is this work necessary? Explain water related issue/problem being solved. **Existing culvert has deteriorated.**

Status

Status	Notes	Date
Approved	None	May 23, 2019
Tabled	None	Dec. 27, 2018
Received	None	Nov. 19, 2018

Conditions

P.A. #18156 – Previously “Tabled” Red Lake Watershed District (RLWD) approval to replace and lengthen, the east culvert of 2 lines, of 36 in. diameter pipes in the existing field entrance. ■ Lengthening/widening of culvert and entrance shall be to the North of what is currently in-place. By lengthening to the north, this will ensure that the field ditch entering from the East, on the south side of the entrance, will not be restricted. ■ Approval of Red Lake County Highway Department must also be obtained and meet their specs/conditions; proposed work is in County Road #119 Right-of-Way. Contact person at Red Lake Co. Hwy. Dept. is Randy Konickson at 218-253-2697. For proposed work on lands not owned by applicant, he/she must obtain, in writing, permission from the affected landowners to perform proposed work. Applicant is responsible for utility locates by calling Gopher 1. (1-800-252-1166)

P.A. #18156 – ‘Tabled’ at 12-27-2018 Brd. Mtg. I recommend this permit be “tabled” until after the 2019 Spring melt. This will allow for adequate time to observe runoff conditions, water elevations, existing culvert sizes and flow patterns. Staff member, Loren Sanderson met with the applicant on Dec. 19, 2018, to discuss the permit, topography, culvert sizes, etc. The out of area landowner/applicant was unaware that there are 2 lines of 36 in. diameter pipes in the existing field entrance permit site.

NOTE: This permit does not relieve the applicant of any requirements for other permits which may be necessary from Township, County, State, or Federal Government Agencies.



Permit # 19-010

Status Report: **Approved**

Applicant Information

Name	Organization	Address	Email	Phone Number(s)
	North Dakota Pipeline Company, LLC	17536 470th Street Clearbrook, MN 56634		tel:218-336-2284 mobile: fax:

General Information

(1) The proposed project is a:

Culvert Installation / Removal / Modification

(2) Legal Description

(3) County: **Clearwater** Township: **Leon** Range: **37** Section: **29 1/4: SE1/4 SW1/4 SE1/4**

(4) Describe in detail the work to be performed. **Install new fencing, moving one gate and installing new gate, installing culverts within an unnamed stream, and constructing a new access road into the station. Culverts were sized to 36" to match culverts under county road.**

(5) Why is this work necessary? Explain water related issue/problem being solved. **Safety reasons. To allow for Enbridge workers to travel between facilities without having to travel onto the county road.**

Status

Status	Notes	Date
Approved	None	May 23, 2019
Received	None	April 16, 2019

Conditions

P.A. #19010 – ND pipeline Co. Red Lake Watershed District (RLWD) approval to install two 36 in. dia. culverts on pipeline property – culvert size is consistent with county road culvert directly upstream of the proposed installations

NOTE: This permit does not relieve the applicant of any requirements for other permits which may be necessary from Township, County, State, or Federal Government Agencies.



Permit # 19-027

Status Report: **Approved**

Applicant Information

Name	Organization	Address	Email	Phone Number(s)
Gerald Hermreck	Numedal Township	None		tel: mobile: 218-689-4020 fax:

General Information

(1) The proposed project is a:

Culvert Installation / Removal / Modification

(2) Legal Description

(3) County: **Pennington** Township: **Numedal** Range: **45** Section: **36 1/4: SW1/4**

(4) Describe in detail the work to be performed.

(5) Why is this work necessary? Explain water related issue/problem being solved.

Status

Status	Notes	Date
Approved	Site A- Approve. Site B- Deny. Site C-Approve.	May 15, 2019
Received	None	April 25, 2019

Conditions

Refer to Site Map- Site A- Red Lake Watershed District (RLWD) approval to put a flap gate on the east end (outlet end) of 18”diameter CMP centerline culvert that is approximately 500’ north of the intersection of 150th Ave NW & 160th St NW. -Approve. Site B- Red Lake Watershed District (RLWD) Denial to put a flap gate on the east end (outlet end) of 18”diameter CMP centerline culvert that is approximately 580’ north of the intersection of 160th Ave NW & 160th St NW. -Deny. Site C- Red Lake Watershed District (RLWD) approval to remove 24” diameter CMP centerline 160th St. NW and replace with 36” diameter culvert.-Approve. For proposed work on lands not owned by applicant, he/she must obtain, in writing, permission from the affected landowners to perform proposed work. Applicant is responsible for utility locates by calling Gopher 1. (1-800-252-1166)

NOTE: This permit does not relieve the applicant of any requirements for other permits which may be necessary from Township, County, State, or Federal Government Agencies.



Permit # 19-028

Status Report: **Approved**

Applicant Information

Name	Organization	Address	Email	Phone Number(s)
Colleen Kaste		11779 410th St. SE Fertile , MN 56540		tel:2189456738 mobile: fax:

General Information

(1) The proposed project is a:

Culvert Installation / Removal / Modification

(2) Legal Description

(3) County: **Pennington** Township: **Rocksbury** Range: **None** Section: **28** 1/4:

(4) Describe in detail the work to be performed. **Replace existing 24" dia. with 18" dia. pipe.**

(5) Why is this work necessary? Explain water related issue/problem being solved. **widen crossing**

Status

Status	Notes	Date
Approved	None	May 10, 2019
Received	None	May 3, 2019

Conditions

Pennington County – Rocksbury Twp. – Section 28 - Red Lake Watershed District (RLWD) approval to replace a 24" diameter driveway culvert and replace with an 18" diameter culvert as per approval of Rocksbury Township specs/conditions; proposed work is within road Right-of Way. -Approve. For proposed work on lands not owned by applicant, he/she must obtain, in writing, permission from the affected landowners to perform proposed work. Applicant is responsible for utility locates by calling Gopher 1. (1-800-252-1166)

NOTE: This permit does not relieve the applicant of any requirements for other permits which may be necessary from Township, County, State, or Federal Government Agencies.



Permit # 19-029

Status Report: **Approved**

Applicant Information

Name	Organization	Address	Email	Phone Number(s)
Bruce Driscoll	Driscoll & Driscoll, Inc.	PO BOX 343 East Grand Forks, MN 56721		tel:218-773-2661 mobile: fax:

General Information

(1) The proposed project is a:

Culvert Installation / Removal / Modification

(2) Legal Description

(3) County: **Polk** Township: **Nesbit** Range: **None** Section: **11 1/4**:

(4) Describe in detail the work to be performed.

(5) Why is this work necessary? Explain water related issue/problem being solved.

Status

Status	Notes	Date
Approved	None	May 14, 2019
Received	None	May 3, 2019

Conditions

Polk County – Nesbit Twp. – Section 11 - Red Lake Watershed District (RLWD) approval to replace a 12” diameter field entrance culvert and replace with an 18” diameter culvert, and also shift entrance to the east approximately 660’ along property line as per approval of Nesbit Township specs/conditions; proposed work is within road Right-of Way. -Approve. For proposed work on lands not owned by applicant, he/she must obtain, in writing, permission from the affected landowners to perform proposed work. Applicant is responsible for utility locates by calling Gopher 1. (1-800-252-1166)

NOTE: This permit does not relieve the applicant of any requirements for other permits which may be necessary from Township, County, State, or Federal Government Agencies.



Permit # 19-030

Status Report: **Approved**

Applicant Information

Name	Organization	Address	Email	Phone Number(s)
Sara L. Faivre	Sara L. Faivre Revocable Trust	2579 County Road 140 Cameron , TX 76520		tel:512-826-2218 mobile: fax:

General Information

(1) The proposed project is a:

Tiling

(2) Legal Description

(3) County: **Red Lake** Township: **Terrebonne** Range: **43** Section: **24 1/4: NE1/4**

(4) Describe in detail the work to be performed. **Install random tile with gravity outflow.**

(5) Why is this work necessary? Explain water related issue/problem being solved. **Improved drainage.**

Status

Status	Notes	Date
Approved	None	May 23, 2019
Received	None	May 3, 2019

Conditions

P.A. #19030 The Red Lake Watershed District (RLWD) approves the pattern tile project with a 'gravity' outlet. If any work is within a public road and/or public ditch Right-of-Way, applicant shall contact the appropriate road/ditch authority for their approval, and must meet their specs/conditions. ie: Terrebonne Twp. and Red Lake Co. Drainage Authority (CD #4) - Kurt Casavan at 218-253-4121. Directly downstream of the tile and/or pump station(s) outlets, applicant shall ensure that adequate grade and drainage is provided. ■ Note: Please be aware of, and review the 'bullet points' on the bottom half of the application. For proposed work on lands not owned by applicant, he/she must obtain, in writing, permission from the affected landowners to perform proposed work. Applicant is responsible for utility locates by calling Gopher 1. (1-800-252-1166)

NOTE: This permit does not relieve the applicant of any requirements for other permits which may be necessary from Township, County, State, or Federal Government Agencies.



Permit # 19-031

Status Report: **Approved**

Applicant Information

Name	Organization	Address	Email	Phone Number(s)
Carolyn J Faivre	Carolyn J Faivre Trust	622 East Illinois Street Wheaton, IL 60187		tel: 630-334-1053 mobile: fax:

General Information

(1) The proposed project is a:

Tiling

(2) Legal Description

(3) County: **Red Lake** Township: **Terrebonne** Range: **43** Section: **13 1/4**:

(4) Describe in detail the work to be performed. **Install random tile with gravity outlet.**

(5) Why is this work necessary? Explain water related issue/problem being solved. **Improved drainage**

Status

Status	Notes	Date
Approved	None	May 23, 2019
Received	None	May 3, 2019

Conditions

P.A. #19031 The Red Lake Watershed District (RLWD) approves the pattern tile project with a 'gravity' outlet. If any work is within a public road and/or public ditch Right-of-Way, applicant shall contact the appropriate road/ditch authority for their approval, and must meet their specs/conditions. ie: Red Lake County Hwy. Dept. (Co. Rd. #117) Contact persons at Red Lake Co. Hwy. Dept. are Engineer Eric Hove or Randy Konickson at 218-253-2697, and Red Lake Co. Drainage Authority (CD #4) - Kurt Casavan at 218-253-4121. Directly downstream of the tile and/or pump station(s) outlets, applicant shall ensure that adequate grade and drainage is provided. ■ Note: Please be aware of, and review the 'bullet points' on the bottom half of the application. For proposed work on lands not owned by applicant, he/she must obtain, in writing, permission from the affected landowners to perform proposed work. Applicant is responsible for utility locates by calling Gopher 1. (1-800-252-1166)

NOTE: This permit does not relieve the applicant of any requirements for other permits which may be necessary from Township, County, State, or Federal Government Agencies.



Permit # 19-032

Status Report: **Approved**

Applicant Information

Name	Organization	Address	Email	Phone Number(s)
David Faivre		None		tel: mobile: fax:

General Information

(1) The proposed project is a:

Tiling

(2) Legal Description

(3) County: **Red Lake** Township: **Terrebonne** Range: **43** Section: **24 1/4: NW1/4**

(4) Describe in detail the work to be performed. **Install random tile, with gravity outlet.**

(5) Why is this work necessary? Explain water related issue/problem being solved. **Improved drainage.**

Status

Status	Notes	Date
Approved	None	May 23, 2019
Received	None	May 3, 2019

Conditions

P.A. #19032 The Red Lake Watershed District (RLWD) approves the pattern tile project with a 'gravity' outlet. If any work is within a public road and/or public ditch Right-of-Way, applicant shall contact the appropriate road/ditch authority for their approval, and must meet their specs/conditions. Ie: Red Lake County Hwy. Dept. (Co. Rd. #14) Contact persons at Red Lake Co. Hwy. Dept. are Engineer Eric Hove or Randy Konickson at 218-253-2697. Directly downstream of the tile and/or pump station(s) outlets, applicant shall ensure that adequate grade and drainage is provided. ■ Note: Please be aware of, and review the 'bullet points' on the bottom half of the application. For proposed work on lands not owned by applicant, he/she must obtain, in writing, permission from the affected landowners to perform proposed work. Applicant is responsible for utility locates by calling Gopher 1. (1-800-252-1166)

NOTE: This permit does not relieve the applicant of any requirements for other permits which may be necessary from Township, County, State, or Federal Government Agencies.



Permit # 19-033

Status Report: **Approved**

Applicant Information

Name	Organization	Address	Email	Phone Number(s)
Carolyn J. Faivre	Carolyn J Faivre Trust	622 East Illinois Street Wheaton, IL 60187		tel: mobile: fax:

General Information

(1) The proposed project is a:

Tiling

(2) Legal Description

(3) County: **Red Lake** Township: **Terrebonne** Range: **43** Section: **35 1/4: NE1/4**

(4) Describe in detail the work to be performed. **Install pattern tile with gravity outlet.**

(5) Why is this work necessary? Explain water related issue/problem being solved. **Improved drainage**

Status

Status	Notes	Date
Approved	None	May 23, 2019
Received	None	May 3, 2019

Conditions

P.A. #19033 The Red Lake Watershed District (RLWD) approves the pattern tile project with a 'gravity' outlet. If any work is within a public road and/or public ditch Right-of-Way, applicant shall contact the appropriate road/ditch authority for their approval, and must meet their specs/conditions. Ie: Terrebonne Twp. Directly downstream of the tile and/or pump station(s) outlets, applicant shall ensure that adequate grade and drainage is provided. ■ Note: Please be aware of, and review the 'bullet points' on the bottom half of the application. For proposed work on lands not owned by applicant, he/she must obtain, in writing, permission from the affected landowners to perform proposed work. Applicant is responsible for utility locates by calling Gopher 1. (1-800-252-1166)

NOTE: This permit does not relieve the applicant of any requirements for other permits which may be necessary from Township, County, State, or Federal Government Agencies.



Permit # 19-034

Status Report: **Approved**

Applicant Information

Name	Organization	Address	Email	Phone Number(s)
Steve Faivre		726 Somonauk Street Sycamore, IL 60178		tel: mobile: 815-761-5070 fax:

General Information

(1) The proposed project is a:

Tiling

(2) Legal Description

(3) County: **Red Lake** Township: **Poplar River** Range: **42** Section: **19 1/4: NW1/4**

(4) Describe in detail the work to be performed. **Install random tile with gravity outflow.**

(5) Why is this work necessary? Explain water related issue/problem being solved.

Status

Status	Notes	Date
Approved	None	May 23, 2019
Received	None	May 3, 2019

Conditions

P.A. #19034 The Red Lake Watershed District (RLWD) approves the pattern tile project with a 'gravity' outlet. If any work is within a public road and/or public ditch Right-of-Way, applicant shall contact the appropriate road/ditch authority for their approval, and must meet their specs/conditions. . ie: Red Lake County Hwy. Dept. (Co. Rd. #14) Contact persons at Red Lake Co. Hwy. Dept. are Engineer Eric Hove or Randy Konickson at 218-253-2697, and Red Lake Co. Drainage Authority (CD #4) - Kurt Casavan at 218-253-4121. Directly downstream of the tile and/or pump station(s) outlets, applicant shall ensure that adequate grade and drainage is provided. ■ Note: Please be aware of, and review the 'bullet points' on the bottom half of the application. For proposed work on lands not owned by applicant, he/she must obtain, in writing, permission from the affected landowners to perform proposed work. Applicant is responsible for utility locates by calling Gopher 1. (1-800-252-1166)

NOTE: This permit does not relieve the applicant of any requirements for other permits which may be necessary from Township, County, State, or Federal Government Agencies.



Permit # 19-035

Status Report: **Approved**

Applicant Information

Name	Organization	Address	Email	Phone Number(s)
	Minnesota Department of Transportation	3920 Hwy 2 West Bemidji, MN 566014		tel:218-755-6527 mobile: fax:

General Information

(1) The proposed project is a:

Bridge Installation / Removal / Modification

(2) Legal Description

(3) County: **Beltrami** Township: **Kelliher** Range: **None** Section: **22 1/4**:

(4) Describe in detail the work to be performed. **Replace bridge #91110, 8339, 88115 with box culverts. Box culverts will be lengthened to eliminate need for guard rail.**

(5) Why is this work necessary? Explain water related issue/problem being solved. **Provide a structurally sound and reliable crossing on TH 72 over south Cormarant River, Sucker Creek and Shotley Brook.**

Status

Status	Notes	Date
Approved	None	May 23, 2019
Received	None	May 3, 2019

Conditions

P.A. #19035 – MnDOT TH #72 Replace existing box culverts, concrete arch pipes and metal arch pipes with new Box culverts - approve

NOTE: This permit does not relieve the applicant of any requirements for other permits which may be necessary from Township, County, State, or Federal Government Agencies.



Permit # 19-036

Status Report: **Approved**

Applicant Information

Name	Organization	Address	Email	Phone Number(s)
	Polk County Highway Department	820 Old Hwy 75 South Crookston, MN 56716		tel: mobile: 218-470-8263 fax:

General Information

(1) The proposed project is a:

Culvert Installation / Removal / Modification

(2) Legal Description

(3) County: **Polk** Township: **Lowell** Range: **47** Section: **30 1/4: NW1/4**

(4) Describe in detail the work to be performed. **Remove existing 30" cmp x 108' long. Replace with new cmp x 108' long.**

(5) Why is this work necessary? Explain water related issue/problem being solved. **Original culvert was installed in 1953. Culvert has rusted and needs to be replaced.**

Status

Status	Notes	Date
Approved	None	May 23, 2019
Received	None	May 8, 2019

Conditions

P.A. #19036 – Polk Co. Ditch Authority – Lowell Twp. sec. 30 Red Lake Watershed District (RLWD) approval to remove existing deteriorated cmp, and install new 36 in. diameter pipe, and stabilize the inlet and outlet end with rock rip-rap. – If the proposed work is a change from the original ditch plan, we recommend that the Ditch Authority conduct a public hearing.

NOTE: This permit does not relieve the applicant of any requirements for other permits which may be necessary from Township, County, State, or Federal Government Agencies.



Permit # 19-037

Status Report: **Approved**

Applicant Information

Name	Organization	Address	Email	Phone Number(s)
	Polk County Highway Department	820 Old Highway 75 South Crookston, MN 56716		tel: mobile: 218-470-8263 fax:

General Information

(1) The proposed project is a:

Culvert Installation / Removal / Modification

(2) Legal Description

(3) County: **Polk** Township: **Gully** Range: **39** Section: **1 1/4: NW1/4**

(4) Describe in detail the work to be performed. **Replace existing culvert at Station 78+65 in County Ditch 88 Branch 1.**

(5) Why is this work necessary? Explain water related issue/problem being solved. **Crossing failure.**

Status

Status	Notes	Date
Approved	None	May 23, 2019
Received	None	May 8, 2019

Conditions

P.A. #19037 – Polk Co. Ditch Authority – Gully Twp. sec. 1 Red Lake Watershed District (RLWD) approval to remove existing deteriorated cmp, and install new 48 in. diameter pipe - If the proposed work is a change from the original ditch plan, we recommend that the Ditch Authority conduct a public hearing.

NOTE: This permit does not relieve the applicant of any requirements for other permits which may be necessary from Township, County, State, or Federal Government Agencies.



Permit # 19-038

Status Report: **Approved**

Applicant Information

Name	Organization	Address	Email	Phone Number(s)
Jerry Hasnedl		821 Taft Street East Thief River Falls, MN 56750		tel: mobile: 218-684-5142 fax:

General Information

(1) The proposed project is a:

Culvert Installation / Removal / Modification

(2) Legal Description

(3) County: **Pennington** Township: **River Falls** Range: **43** Section: **2 1/4: NW1/4**

(4) Describe in detail the work to be performed. **Replace existing culvert. Work is in south ditch of Pennington County Hwy #3.**

(5) Why is this work necessary? Explain water related issue/problem being solved. **Culvert damaged and crossing washed out.**

Status

Status	Notes	Date
Approved	None	May 23, 2019
Received	None	May 8, 2019

Conditions

P.A. #19038 Red Lake Watershed District (RLWD) approval to replace existing 24 in. dia. field entrance culvert with the same diameter, at approx. the same elevation, as per approval of Pennington County specs/conditions; proposed work is in County Hwy. #3 Right-of-Way. Contact person at Pennington Co. Hwy. Dept. are Engineer Mike Flaagen at 218-683-7017. For proposed work on lands not owned by applicant, For he/she must obtain, in writing, permission from the affected landowners to perform proposed work. Applicant is responsible for utility locates by calling Gopher 1. (1-800-252-1166)

NOTE: This permit does not relieve the applicant of any requirements for other permits which may be necessary from Township, County, State, or Federal Government Agencies.



Permit # 19-039

Status Report: **Approved**

Applicant Information

Name	Organization	Address	Email	Phone Number(s)
Jerry Hasnedl		821 Taft St. E Thief River Falls, MN 56701		tel: mobile: 218-684-5142 fax:

General Information

- (1) The proposed project is a:
Culvert Installation / Removal / Modification
- (2) Legal Description
- (3) County: **Pennington** Township: **River Falls** Range: **None** Section: **2 1/4**:
- (4) Describe in detail the work to be performed.
- (5) Why is this work necessary? Explain water related issue/problem being solved.

Status

Status	Notes	Date
Approved	None	May 10, 2019
Received	None	May 8, 2019

Conditions

Pennington County – River Falls Twp. – Section 2 - Red Lake Watershed District (RLWD) approval to replace a 18” diameter field entrance culvert and replace with an 18” diameter culvert as per approval of Riverfalls Township specs/conditions; proposed work is within road Right-of Way. -Approve. For proposed work on lands not owned by applicant, he/she must obtain, in writing, permission from the affected landowners to perform proposed work. Applicant is responsible for utility locates by calling Gopher 1. (1-800-252-1166)

NOTE: This permit does not relieve the applicant of any requirements for other permits which may be necessary from Township, County, State, or Federal Government Agencies.



Permit # 19-040

Status Report: **Approved**

Applicant Information

Name	Organization	Address	Email	Phone Number(s)
Jeff Novak		17858 240th Street NW Viking, MN		tel: mobile: 218-280-5515 fax:

General Information

(1) The proposed project is a:

Culvert Installation / Removal / Modification

(2) Legal Description

(3) County: **Pennington** Township: **Rocksbury** Range: **43** Section: **20** 1/4: **SE1/4**

(4) Describe in detail the work to be performed. **Install culvert and driveway.**

(5) Why is this work necessary? Explain water related issue/problem being solved. **New site for house.**

Status

Status	Notes	Date
Approved	None	May 23, 2019
Received	None	May 9, 2019

Conditions

P.A. #19040 Red Lake Watershed District (RLWD) approval to install a new driveway entrance and 15 in. diameter culvert as per approval of Rocksbury Township specs/conditions; proposed work is within township road Right-of Way. For proposed work on lands not owned by applicant, he/she must obtain, in writing, permission from the affected landowners to perform proposed work. Applicant is responsible for utility locates by calling Gopher 1. (1-800-252-1166)

NOTE: This permit does not relieve the applicant of any requirements for other permits which may be necessary from Township, County, State, or Federal Government Agencies.



Permit # 19-041

Status Report: **Approved**

Applicant Information

Name	Organization	Address	Email	Phone Number(s)
Michael G. Davidson		None		tel: mobile: 218-521-0983 fax:

General Information

(1) The proposed project is a:

Culvert Installation / Removal / Modification

(2) Legal Description

(3) County: **Polk Township: Crookston Range: 46 Section: 15 1/4: NW1/4**

(4) Describe in detail the work to be performed. **Install 18" culvert.**

(5) Why is this work necessary? Explain water related issue/problem being solved. **Gain access to land for home construction.**

Status

Status	Notes	Date
Approved	None	May 23, 2019
Received	None	May 13, 2019

Conditions

P.A. #19041 Red Lake Watershed District (RLWD) approval to install an entrance with an 18 in. diameter culvert as per approval of Crookston Township specs/conditions; proposed work is within township road Right-of Way. For proposed work on lands not owned by applicant, he/she must obtain, in writing, permission from the affected landowners to perform proposed work. Applicant is responsible for utility locates by calling Gopher 1. (1-800-252-1166)

NOTE: This permit does not relieve the applicant of any requirements for other permits which may be necessary from Township, County, State, or Federal Government Agencies.



Permit # 19-045

Status Report: **Approved**

Applicant Information

Name	Organization	Address	Email	Phone Number(s)
El-Rio Wishard		26876 340th Avenue SE Trail, MN 56684		tel: 218-238-4845 mobile: 218-268-4014 fax:

General Information

(1) The proposed project is a:

Culvert Installation / Removal / Modification

(2) Legal Description

(3) County: **Pennington Township: Hickory Range: 39 Section: 28 1/4: NW1/4**

(4) Describe in detail the work to be performed. **Site 1 - install centerline pipe (24" diameter) in Pennington County Road #1. Site 2 - Install centerline pipe (18" diameter) in Hickory Township Road (390th Avenue SE)**

(5) Why is this work necessary? Explain water related issue/problem being solved. **Improve drainage on field-no longer in CRP.**

Status

Status	Notes	Date
Approved	None	May 23, 2019
Received	None	May 20, 2019

Conditions

P.A. #19045 Red Lake Watershed District (RLWD) approval to install two centerline road culverts per approval of both Hickory Township and Pennington County Hwy. Dept. specs/conditions; proposed work is within public road Right-of Way. ■ (Site #1) see map – install 24 in. dia. centerline culvert, Pennington County Road #1 ■ (Site #2) see map – install 18 in. dia. centerline culvert, Hickory Twp. Road (390th Ave. SE) Contact person at Pennington Co. Hwy. Dept. is Engineer Mike Flaagen at 218-683-7017. For proposed work on lands not owned by applicant, For he/she must obtain, in writing, permission from the affected landowners to perform proposed work. Applicant is responsible for utility locates by calling Gopher 1. (1-800-252-1166)

NOTE: This permit does not relieve the applicant of any requirements for other permits which may be necessary from Township, County, State, or Federal Government Agencies.

Shopping Cart

Key Code/Coupon

If you have a promotion / key code, please enter it here, then update to see your savings.

Quick Cart

Already have a Forestry Suppliers stock number? Enter it here to automatically add it to your cart.

	Qty	Item#	Name	Price	Item Total	Remove
	<input type="text" value="5"/>	90702	Onset HOBO U20 Water Level Logger, 100' Range In Stock	\$495.00	\$2,475.00	
Subtotal:					\$2,475.00	
				Zip Code: Thief River Falls, MN	<input type="text" value="56701"/>	
					<input type="button" value="Estimate Shipping"/>	
				Shipping:	\$37.50	
				Discount:	(\$247.50)	
				Total:	\$2,265.00	

Learn about Forestry Suppliers' [Return Policy](#).



Shopping Cart

Key Code/Coupon

If you have a promotion / key code, please enter it here, then update to see your savings.

Quick Cart

Already have a Forestry Suppliers stock number? Enter it here to automatically add it to your cart.

	Qty	Item#	Name	Price	Item Total	Remove
	<input type="text" value="6"/>	90702	Onset HOBO U20 Water Level Logger, 100' Range In Stock	\$495.00	\$2,970.00	
Subtotal:					\$2,970.00	
				Zip Code: Thief River Falls, MN	<input type="text" value="56701"/>	
					<input type="button" value="Estimate Shipping"/>	
				Shipping:	\$42.02	
				Discount:	(\$297.00)	
				Total:	\$2,715.02	

Learn about Forestry Suppliers' [Return Policy](#).



Water Quality Equipment:

Shopping Cart

Key Code/Coupon

If you have a promotion / key code, please enter it here, then update to see your savings.

Quick Cart

Already have a Forestry Suppliers stock number? Enter it here to automatically add it to your cart.

	Qty	Item#	Name	Price	Item Total	Remove
	<input type="text" value="7"/>	90702	Onset HOBO U20 Water Level Logger, 100' Range In Stock	\$495.00	\$3,465.00	
Subtotal:					\$3,465.00	
Zip Code: Thief River Falls, MN				<input type="text" value="56701"/>		
				<input type="button" value="Estimate Shipping"/>		
Shipping:					\$45.83	
Discount:					(\$346.50)	
Total:					\$3,164.33	

Learn about Forestry Suppliers' [Return Policy](#).



Engineering Equipment:

ORDER ESTIMATE
ESTIMATE DATE: 5/16/19

ORDER#:

FORESTRY SUPPLIERS, INC.
205 W RANKIN ST.
JACKSON MS 39201
1-800-647-5368

MN 56701

ITEM#	Q/O	U/M	DESCRIPTION	PRICE	EXT PRICE
2261	4	EA	LIGHT BAR,MINI,13.5"LOWPROFILE	169.950	679.80

DISC %: .000
 ZONE: 6 TOT WGT: 29.780 UPS GROUND SAVER
 TOT PKG: 1

MDSE AMT: 679.80
 DISC AMT: .00
 FRT AMT: 36.83
 PKG CHG: .50
 MISC AMT: .00
 TAX AMT: .00
 HANDLING: 3.00

AMT SUB TAX: 720.13 TAX JURISDICTION:

INVOICE AMT: 720.13

SALES PERSON: ALLISONE

MAWD SUMMER TOUR

MN Association of Watershed Districts, 595 Aldine St, St. Paul MN 55104
(651) 440-9407 office | www.mnwatershed.org | [@mnwd46](https://www.facebook.com/mnwd46) | [facebook.com/mnwd46](https://www.facebook.com/mnwd46)



MAWD would like to thank this year's tour hosts: the Red River Basin Commission, Red River Watershed Management Board, Buffalo Red River Watershed District, Bois de Sioux Watershed District, Red River Retention Authority, and Red River Joint Resource District. THANK YOU!

Wednesday, June 26, 2019 Meetings, Social, and Dinner



9-noon MN Association of Watershed Administrators Meeting
1-4 p.m. MAWD Board of Directors Meeting
4-6 p.m. Registration (Shuttles start leaving the Marriott at 5 p.m.)
6-9 p.m. Social and Dinner at the Hjemkomst Center, the home of the Hjemkomst Viking Ship! Mark Peihl, Red River Historian, will discuss the history of the steamboat industry on the Red and other fun historical river facts. We will also have presenters from River Keepers and take a short walk down to the river. Other tours of the museum and ship will be offered throughout the evening.

Thursday, June 27, 2019

Red River Basin Bus Tour (Minnesota and North Dakota sites)



7-8 a.m. Registration (Buses will depart the Marriott at 8:30 a.m.)
8:30 a.m.-5 p.m. Bus Tour
Hop on the bus for an up close and personal look at some exciting projects in the Southern Red River Basin in both Minnesota and North Dakota. The projects showcase benefits for water quality, drainage, flood damage reduction, soil conservation, and fish, wildlife and outdoor recreation. We will also be having lunch at one of the Minnesota's Discovery Farms - Nordick Farm.

Friday, June 28, 2019

Spotlight on the Red River Basin Workshop



8:30-11:30 a.m. Presentations at the Marriott, Moorhead
This session will include presentations on the 2019 flood, along with an overview of the efforts to provide flood protection in the rural areas, as well as large cities like Fargo and Moorhead. Hear how multiple watersheds, states, and countries work together to plan and implement flood reduction projects, including an overview of the Fargo-Moorhead Diversion Project.

Hotel Accommodations and Registration Details

Call the Courtyard by Marriott-Moorhead directly at (218) 284-1000 for \$129/night reservations using code MNW. The discounted hotel rate expires May 25, 2019. Visit www.mnwatershed.org/summer-tour to register for events.

Red Lake Watershed District - Administrators Report

May 23, 2019

Red River Watershed Management Board – LeRoy, Allan and I attended the RRWMB meeting held 9:30 am on May 21, 2019 at the University of Minnesota Crookston. Some of the highlights from the RLWD perspective is they officially approved the Funding Agreement and Resolution for the Thief River Westside FDR Project.

Red Lake Watershed District Ditch #16 – I was informed by West Polk SWCD Wetland Conservation Act Specialist that we are to complete a delineation of wetlands near the outlet at the Grand Marais to determine the impacts for the project. I have reached out to Houston Engineering wetland folks to give me a quote to complete this project. All this stems from our Joint Permit application for the project. I should also add that the cultural survey required by the Corps has been completed and we expect a report from the Archaeologist soon.

Red River Valley FDRWG Meeting – I attended a portion of the meeting which included the project readiness form for the Black River Impoundment. The result was the FDRWG approving the report and recommending this project for funding from the State of Minnesota Flood Hazard Mitigation funding.

Area 1 Envirothon – I have included in your packet, a thank from West Polk and Pennington SWCD for our donation to their event.

Dockside Clearwater Lake Area Association – I have included a newsletter from Jean Chadwick, President of Clearwater Lake Area Association, for your review. The newsletter includes various activities and events that are occurring this summer.



West Polk Soil & Water Conservation District

528 Strander Avenue
Crookston, Minnesota 56716-2912
Telephone: 1-218-281-6070 ext. 4
www.westpolkswcd.com

AN EQUAL OPPORTUNITY EMPLOYER

May 8, 2019

Dear Envirothon Sponsor:

On behalf of the West Polk Soil & Water Conservation District (SWCD), we would like to thank you for your generous contribution to the 2019 Area 1 Envirothon.

We are pleased to announce the following winning teams:

- 1st Place - Waubun High School
- 2nd Place - Crookston High School
- 3rd Place - Waubun High School

These top 3 teams qualified for the state competition that will take place May 20th, 2019, at Oliver Kelley Farm, Elk River, MN.

Your generous support makes it possible to continue this area and state outdoor environmental learning event for high school students in northwest Minnesota.

You can see your name/business recognized on our website - www.westpolkswcd.com and our Facebook page - www.facebook.com/WPSWCD

Thank you again.

Sincerely,

Nicole Bernd
District Manager

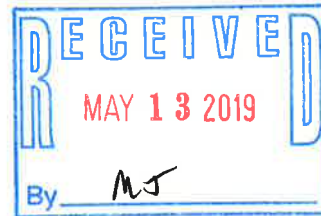

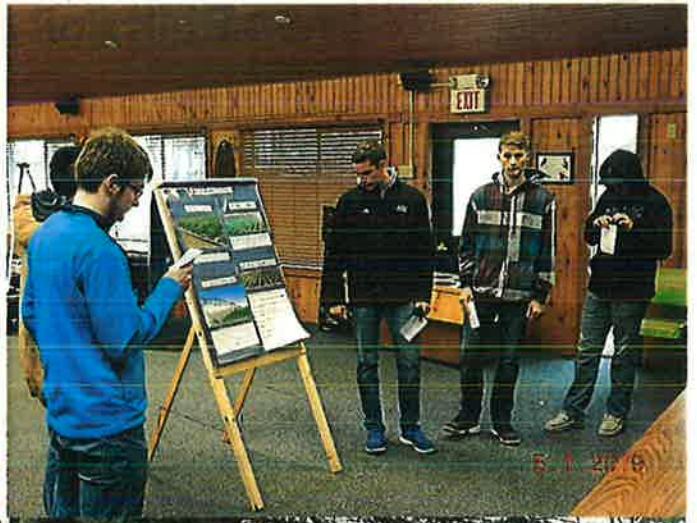
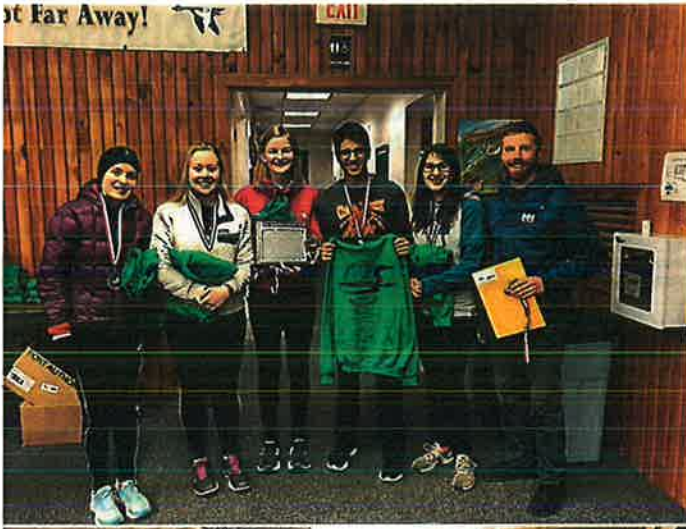

Thank you so much for your
Sponsorship gift of \$300.00 for the
Area 1 Envirothon. Your continued
Support of this fun outdoor
Learning event for our high school
Students is greatly appreciated.

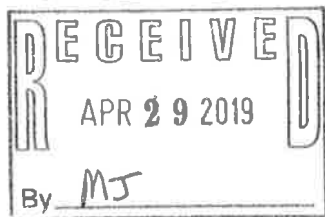

Pennington SWCO

DOCKSIDE



Vol. 10 Issue 1

May 2019

www.minnesotawaters.org/clearwaterlakearea

A message from the President – Jean Chadwick

Last summer the DNR Fisheries did a fish survey on our lake. We had preliminary results at our fall meeting. Gary Barnard will be our guest speaker at the May 26th meeting. He will provide us with the final results of the survey. Gary has provided a copy of the final report, he will review with us at the meeting. There is a link to the document in this newsletter and the link will take you to the document that is on our website. If you are receiving our newsletter via snail mail, please go on line to our website to access the report. Gary will have a few copies with him at our meeting.

I continue to expand my knowledge of AIS through education and volunteer hours. I will be supplementing AIS education at our access this summer outside of the paid inspector hours. I haven't set times yet as I need to complete the AIS Ambassador training in Park Rapids on June 6th from 1 – 4 pm. If you are interested in taking the class please contact Mike Bolinski at 218-739-7576 or michael.bolinski@state.mn.us. I'll have a Zebra Mussels trap for you see. One would be easy to duplicate and hang from your dock. Currently Chester Powell from Clearwater County hangs one from the public access dock and checks throughout the summer and fall.

Bruce Anspach is working on a grant with Minnesota Lakes and Rivers Advocates for a CD3 unit that would be put at a public access in Beltrami County that has Starry Stonewort. Another volunteer opportunity is the Starry Trek which will be held this year on August 17th. Registration for this event will be available on the University of MN Extension Website.

There is a need for volunteers at the 40th Anniversary Debs 4th of July Parade. To help with parking either with or without an ATV contact Donnie Moe at 218-766-1906. Russ Johnson is in charge of Registration and Line-up (Judi is one of our Social Committee Co-Chairs) Is there any interest in a float or some sort of representation from our lake association for the parade? Bring your ideas to our meeting.

I only have one more letter to write this fall as your president. I'll be working on securing a speaker for our fall meeting and am excited to have Gary Barnard at our spring meeting. Let's show him how much we appreciate their work on our lake by showing up in numbers. Contact your neighbors and encourage them to attend and join our association!

*We salute all those who have served and those who
are in service now!
Happy Memorial Day to All!*

A vertical poster for Memorial Day. At the top is a red star on a blue background. Below it, the text 'MEMORIAL DAY' is in a large, serif font. Underneath are three stars, followed by 'Weekend Meeting and Pot Luck Meal' in a smaller serif font. Another set of three stars is below that, followed by 'SUNDAY, MAY 26TH' in a large, bold, serif font. The background of the poster is a gradient of blue and white with light rays at the bottom. There are several blue and yellow rectangular boxes containing text.

Moore's Garage
(8 houses east of the public access)

★ ★ **Guest Speaker: Gary Barnard** ★ ★
Bemidji Area Fisheries Supervisor

Board Meeting: 3:00 p.m.
Pot Luck Meal: 5:00 p.m.
General Meeting follows the meal

Bring your favorite dish to pass
along with plates, utensils and
lawn chair – coffee and
lemonade provided

ALL MEMBERS AND NON-MEMBERS ARE WELCOME!

Happy Memorial Day!
TO THOSE WHO
COURAGEOUSLY
GAVE THEIR LIVES...
AND THOSE WHO
BRAVELY FIGHT
TODAY... THANK
YOU

Jean Chadwick
President
jcchadwick@outlook.com

Skip Anderson
Vice President & Loons
clrwr34@aol.com

Bill Johnson
Treasurer
bill.johnson60@comcast.net

JoLynn Chadwick
Secretary-Web
jjchadwick@q.com

Bruce Bjerke
Board Member, Loons
& Water Quality
bbjerke@clearwater-polk.com

Fred Sundquist
Board Member
wisdom@gvtel.com

Roz Johnson
Lady Slipper Project
rjohnson2122@comcast.net

**CLAA is a
501 (c) (3) non-profit
organization.
Membership dues
and all donations
are fully tax deductible.**

EIN # 41-1936608

THE ICE GOES ON and the Ice Goes Off!

The winter seemed so very long. We definitely felt we were in Minnesota...when you put more miles on the snowblower than on the car!

The ice went on Clearwater Lake November 20, 2018 and Bill Johnson claimed a victory with his ice on date of November 28. Way to go Bill! Congratulations!!

With the snow and ice behind us (we hope), we are anxiously awaiting for the ice to leave us once again and to hear the sweet sound of the loon.

According to various lake resident reports, the date of April 25 is officially the ice-out date on the lake. Contest winner is Deb Bjerke for her spot on guess. Congratulations to Deb!

LOON Update

by JoLynn Chadwick

I have been volunteering as a Loon Watcher for the Minnesota DNR since 2004 and each spring I eagerly wait for the mailing announcing the program for the coming year. This year when opening the envelope, which I noticed was not the same size, I wondered what I would find inside. It was only a letter informing all loon watcher volunteers that the Volunteer Loon Watcher Survey program would be ending. Here are some key components of the letter:

- Minnesota Loon Watcher Survey began in 1979 with 56 volunteers on 73 lakes and has grown to more than 300 volunteers on 450 to 400 lakes.
- More than 10,000 individual surveys reported over the years providing the DNR with incredible and unparalleled data providing essential insights into Minnesota loon biology, behavior and population characteristics.
- In next several months, the program objectives will be re-evaluated and options considered for a relaunching of the survey program with the development of a revised database platform, all with the hope to restart the volunteer survey program in the near future.
- Over the next several months, the data received from the past two seasons will

be organized, compiled and analyzed to give some insights into the health of our state's loon population.

After reading this letter and reading it again and again, I thought to myself... there just might be a connection to a press release appearing in the Brainerd Dispatch dated October 9, 2018:

Minnesota loons may get \$7.2 million from BP oil spill settlement

WASHINGTON, D.C.—Projects to bolster conservation efforts for Minnesota loons will get a huge boost under a settlement agreement announced Tuesday, Oct. 9, stemming from the 2010 Deepwater Horizon oil spill in the Gulf of Mexico.

The agreement, published Tuesday in the Federal Register, sets aside \$16 million from BP, the oil rig's owner, for fish and wildlife rehabilitation for species impacted by the explosion, fire and spill that killed 11 people, injured 17 others and sent millions of gallons of oil into the Gulf.

Minnesota loons spend their winters in the Gulf of Mexico—and Minnesota-born loons spend their second entire year there—before heading north to mate and raise their young.

Under the "Open Ocean" portion of the BP settlement, Minnesota loon restoration would get \$7.2 million. Minnesota's plan includes using the settlement money to buy conservation easements or critical loon habitat on Minnesota lakes shorelines to ensure they have quality nesting areas.

continued on page 3

Loon Update...continued from page 2

Money could also go to lake associations to help loons and to promote non-toxic fishing tackle. Small lead sinkers and jigs used by anglers are known to cause lead poisoning in loons that ingest the tackle thinking they are pebbles they need to help digest their food.

The settlement published Tuesday means federal agencies directed to dole out the BP settlement have agreed on how to spend it. The proposal also would give North and South Dakota \$6.25 million to bolster black terns, while another \$2.15 million will go to help recover gulf sturgeon.

About 900 loons were killed in the spill directly, but many more may have been contaminated. Minnesota researchers fitted loons with tracking devices and discovered they dive to the bottom of the Gulf to feed. Researchers also took blood and feather samples to determine contaminant levels. They discovered chemicals from the oil spill, and the chemicals used to disperse oil from the surface, in many Minnesota loons.

Biologists remain uncertain how the oil spill and residual impact may have impacted Minnesota's summer loon population, but they made a compelling enough case for loon conservation efforts to be included in the final BP settlement.

In 2015 BP agreed to the largest settlement in U.S. history, paying more than \$18 billion to restore natural resources damaged by the oil spill. Most of the money went to the five states along the Gulf of Mexico. But Minnesota's long-time non-game wildlife coordinator, Carrol Henderson, convinced state officials to submit a request, the only one to help migratory waterfowl in a non-Gulf state.

"This is a great day for loons in Minnesota. We have an arrangement that will provide for long-term protections and help increase loon populations," Henderson said Tuesday.

Minnesota has about 12,000 loons, the most of any U.S. state except Alaska.

The settlement still must clear a 30-day public comment period before becoming final. Henderson, who retired just last week from the DNR, said additional rounds of funding could be available in future years until the U.S. Fish and Wildlife Service determines Minnesota loons have overcome any problems caused the oil spill.

Source: *Brainerd Dispatch*, by John Myers; October 9, 2018



– SAVE THE DATES – CLAA 2019 SUMMER SOCIAL EVENTS

BACKYARD GAME PARTY

Saturday, July 20th
1:00 to 4:00

Fun-filled and family-friendly competition involving backyard lawn games.

Bring a lawn chair, your own beverages and a snack for sharing. Open to all CLAA members, their families and guests. Location to be determined by the spring CLAA meeting.



THIRD ANNUAL FLOAT PARTY

Saturday, August 17 – 1:00 p.m.

Fire up your pontoon or boat! We'll meet in the middle of the lake at 1 p.m. Bring your own beverage and a dish to share. Food will be passed from boat/pontoon to boat/pontoon.

Don't have a boat? No problem...be at the public access dock at 1 p.m. and you'll be picked up.

If raining or storming at 1p.m. the party will be cancelled.



Questions about the events, please contact:

Judi Johnson judij@jemco-maxair.co
Carol Torgerson lescarol@gvtel.com
Rachell Ricke rachelle.ricke@gmail.com

Mark Your Calendars!!!!

Sunday May 26 CLAA Meeting and Pot Luck Meal

with guest speaker

Gary Barnard

from the Bemidji Area Fisheries.

**...with explanation, and an in depth
reporting about fishing on
Clearwater Lake.**

Click Here to See The Full Report

AIS Specialist for our region:

Nicole Kovar, *Invasive Species Specialist*
Ecological & Water Resources
218-732-8960

If anything is looking suspicious...take note of the exact location; take a photo or keep a specimen; **then call the specialist.**



Do you have a favorite story or photo you'd like to share with your fellow Association members?

Maybe you experienced something memorable from one of your weekends at the lake.

If so, contact jjchadwick@q.com and it will be shared in the fall issue of the Dockside.



FOR SALE

Vintage white Crosley metal sink base with drawers and storage compartments. White enameled cast iron double sink with counters on each side sits on top of the base (faucet included). Unit is 65" wide. Also 2-3 shelf, matching metal cupboards with doors. All in good condition. Call 218-776-3657 and leave message on how to return your call.



FOR SALE

WEED CUTTING MACHINE

Crary Weed Roller with 3-10' roller sections

See manufacturer website at www.weedroller.com

The machine has been updated several times per manufacturer recommendations and is in good working condition \$500

Contact Skip Anderson, clrwtr34@aol.com for more information or call 218-776-3657. If no answer please leave your return information on machine.

ECOFOOTPRINT GRANT project follow-up

Shoreline Restoration

CHADWICK PROJECT EAST SIDE OF CLEARWATER LAKE (Beltrami County)



Four properties were involved in the Ecofootprint Grant. Two properties are listed below (page 5) and a third property is on page 6. The shoreline restoration projects on page 5 were completed by Mr. Canoe's Natural Resource Service from Grand Rapids, MN; the project on page 6 was completed by Cory Bowman.

The coming of spring should produce a showcase of native plantings along the shoreline of all properties.

Click on the movie icon at the bottom of the page. It will open a time-lapse video of the project on Mike and Nancy Mason's property. The video clip will also be available for viewing from the CLAA website.

MASON PROJECT WEST SIDE OF CLEARWATER LAKE (Clearwater County)



click here to view time-lapse video



video courtesy of Mr. Canoe's
Natural Resource Service
video editor: Paul Perincheff

Restoration can have numerous meanings, but in my mind, restoration is just that, an attempt to return something to its original state. Shoreline restoration, in my mind, is no different. Shoreline restoration shouldn't be thought of in terms of a one size fits all, but rather a mix of different measures that can be taken to ensure stabilization, habitat, and aesthetics.

Often shoreline restoration is a mix of ensuring that aquatic vegetation stays in place where practical, managing water and vegetation upland, as well as providing a solid buffer of native plants along the shore edge. Many of these measures can be applied in a sensible and aesthetically pleasing way and will work together to mitigate

anything that the wind, rain and ice can throw at it.

One method that I like to employ along shorelines is to use coconut fiber logs, a thick, natural fiber netting, backfill behind the logs and a mix of native plants. The logs will blend in to the bank and slowly biodegrade as the native, deep-rooted plants take hold behind the logs.

This is an incredibly effective way to reclaim your shore without the over-the-top expense of rock. This method will also guard against ice push better than rock as well as provide a great deal of incredibly important riparian habitat for many beneficial critters. Not to mention the fact that it provides a great discussion point at your next outdoor cook out!

by **JEFF POENIX**

Mr. Canoe's Natural Resource Service
218-256-6355

ECOFOOTPRINT GRANT project follow-up

Shoreline Restoration

...Continued from page 5

SHRIVER PROJECT

EAST SIDE OF CLEARWATER LAKE
(Beltrami County)



Picture taken before the start of the project



Project contractor:
Cory Bowman

The restoration went well. The County was good to work with. The plantings are springing up!!

- Joel and Shani Shriver

BRUCE BJERKE loon super hero

Friday, May 3, 2019
Email communication from Bruce Bjerke

Look what I found leaving home this morning. Not a good spot for a loon!

Just around the corner from home, the loon was in the ditch, so I stopped to check to see if it was hurt. When I got close, it came after me a couple times, so I knew it wasn't hurt to bad. I knew it was way too far to try steer it back to the lake, so I went home and got a landing net. When I got back, it was in the highway.

It came after me a couple more times, but was able to get it in the landing net with the wings folded in so I could put it in the trunk. Drove it down to the dam and was able to release it by Goudge's dock. Swam off and thankfully seemed just fine.

Interesting, but good start to my day!



Knowledge is POWER

Be sure to check out the links below...

Starry stonewort is Minnesota's newest aquatic invader. Hear from MAISRC (Minnesota Aquatic Invasive Species Research Center) faculty and graduate students about what's known, what's unknown, and what we're doing about it in this video.

<https://www.youtube.com/watch?v=K-Psy-q5VXc&feature=youtu.be>

What happens to walleye when zebra mussels and spiny waterflea invade a lake? This project is researching the impacts that AIS have on food webs, so that managers can better project realistic levels of walleye production and harvest. Watch this video to get an inside-peek into the research!

<https://www.youtube.com/watch?v=dN9slzj6L8&feature=youtu.be>



By Corey Hanson, Red Lake Watershed District Water Quality Coordinator. 5/22/2019.

- ✓ Clearwater River Watershed Restoration and Protection Strategy
- ✓ Red Lake River Watershed Restoration and Protection Strategy
- ✓ Thief River Gage Analysis

Red Lake Watershed District (RLWD) Long-Term Monitoring Program

Entry and submittal (to the MPCA) of 2018 RLWD monitoring data was completed in November. The RLWD reimbursed the Maple Lake Improvement District for their 2018 sample analysis expenses.

Clearwater River Watershed Restoration and Protection Strategy (WRAPS) Project

- Objective 9 – Civic Engagement
 - A presentation was prepared for the November 28, technical advisory committee meeting.
 - A technical advisory meeting was held on November 28, 2018 to discuss restoration and protection strategies for the Clearwater River Watershed.
 - Completed sections of the TMDL and WRAPS were shared with the core team of technical advisors
- Objective 10 – Report Writing
 - RLWD staff worked on editing Section 3 of the Clearwater TMDL
 - Long Lake’s summer average total phosphorus concentrations were recalculated using the 2018 data that met standards, but the addition of the new data wasn’t enough to bring the average significantly closer to meeting the 30 ppb standard.
 - Actions were added to the lists of restoration and protection strategies for the WRAPS report based on information in the Clearwater River Watershed Monitoring and Assessment Report.
 - The total suspended solids TMDL section was nearly completed, except for a map of sites where TMDLs were established.
 - *E. coli* load duration curves were edited.
 - Maps were created for each HUC10 subwatershed.
 - Population trends in the watershed were summarized.

RED LAKE WATERSHED DISTRICT MONTHLY WATER QUALITY REPORT

November-
December 2018

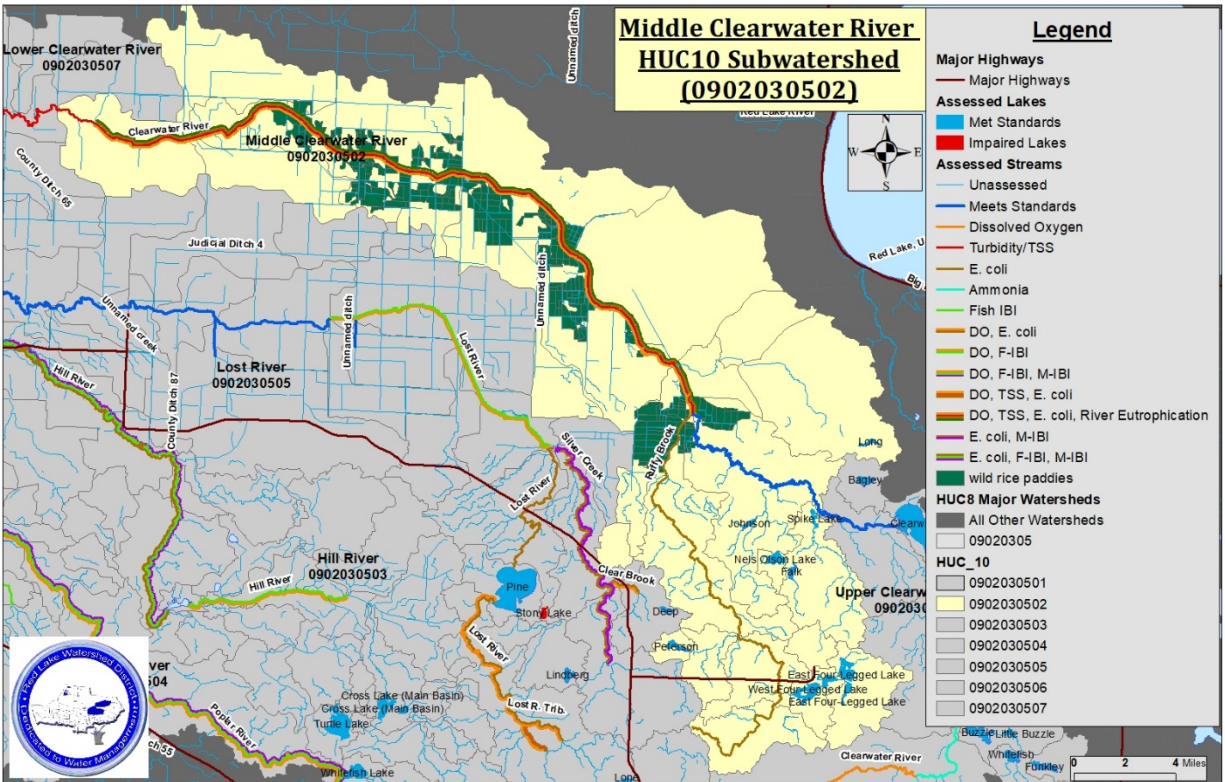
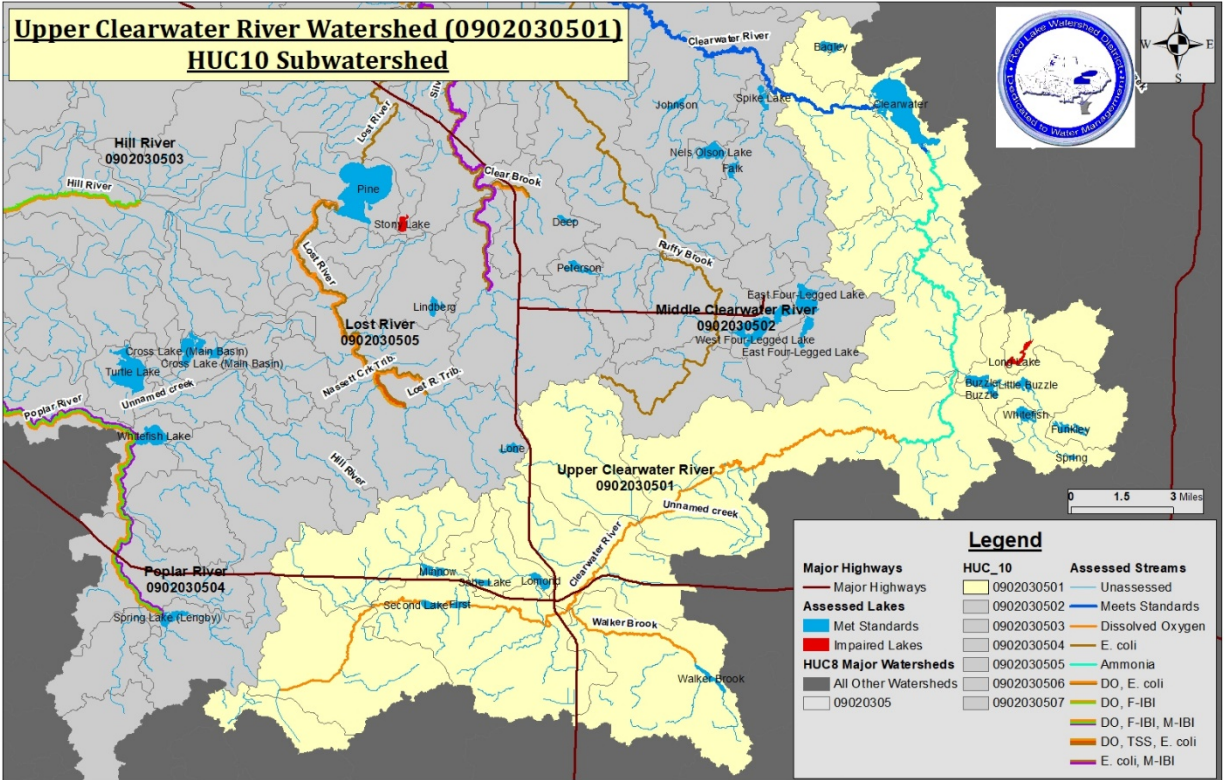

RED LAKE WATERSHED DISTRICT MONTHLY WATER QUALITY REPORT

November-
December 2018

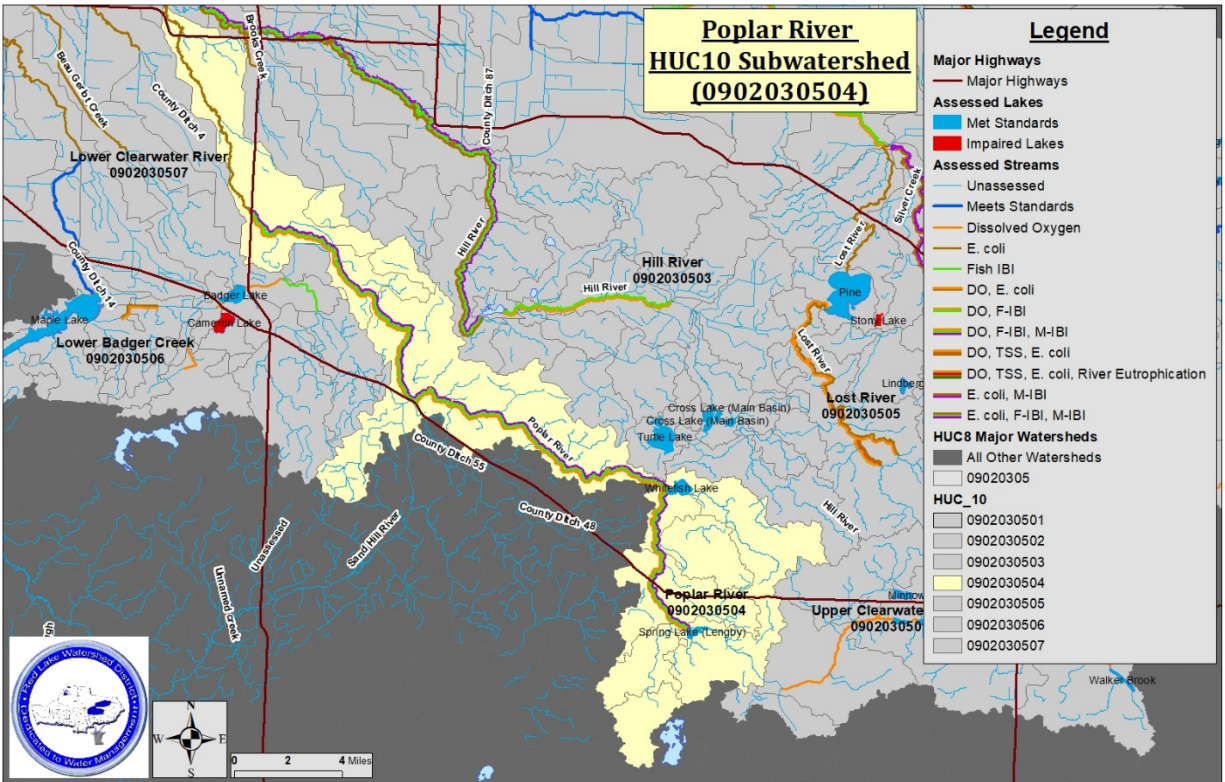
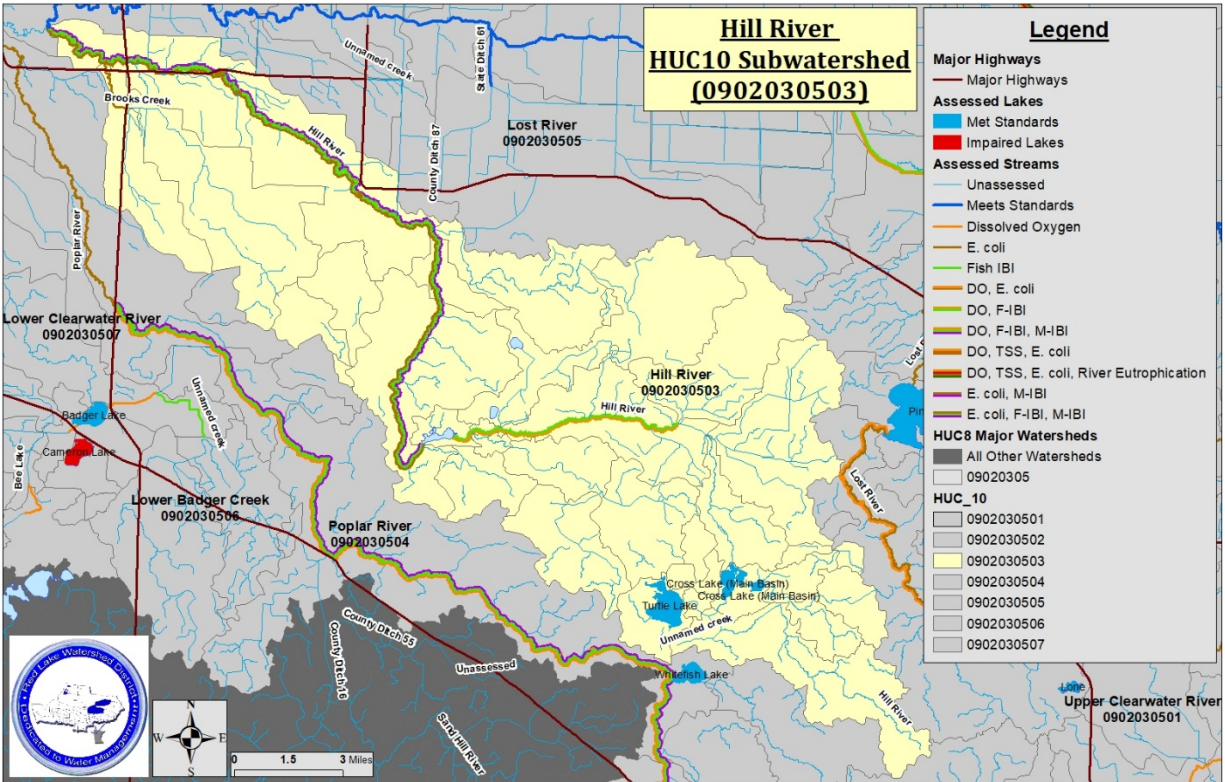

RED LAKE WATERSHED DISTRICT MONTHLY WATER QUALITY REPORT

November-
December 2018

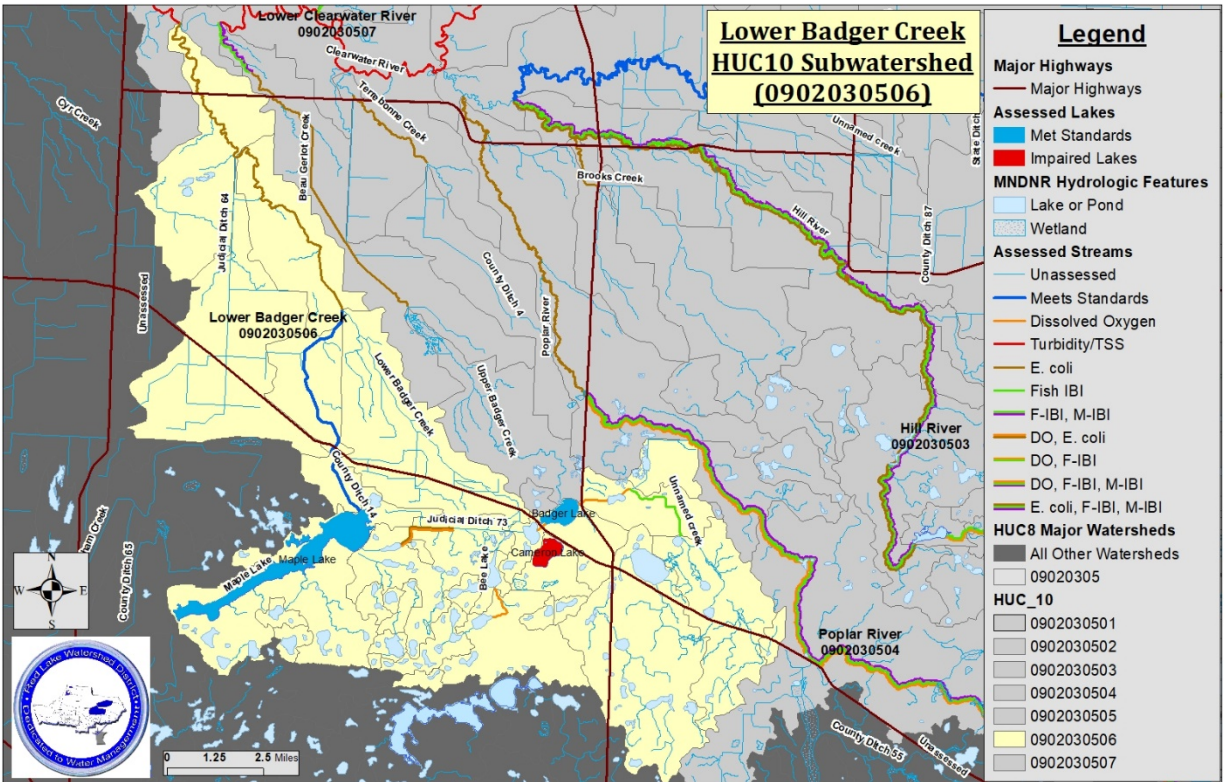
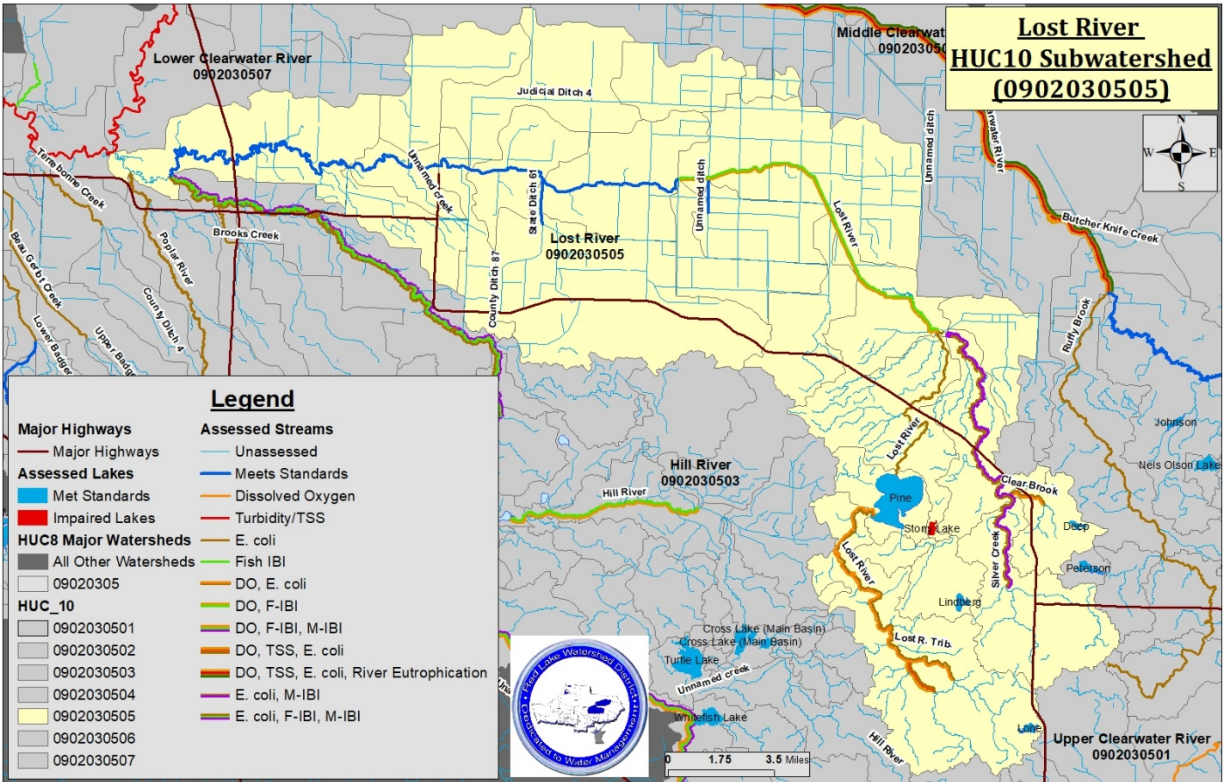

RED LAKE WATERSHED DISTRICT MONTHLY WATER QUALITY REPORT

November-
December 2018

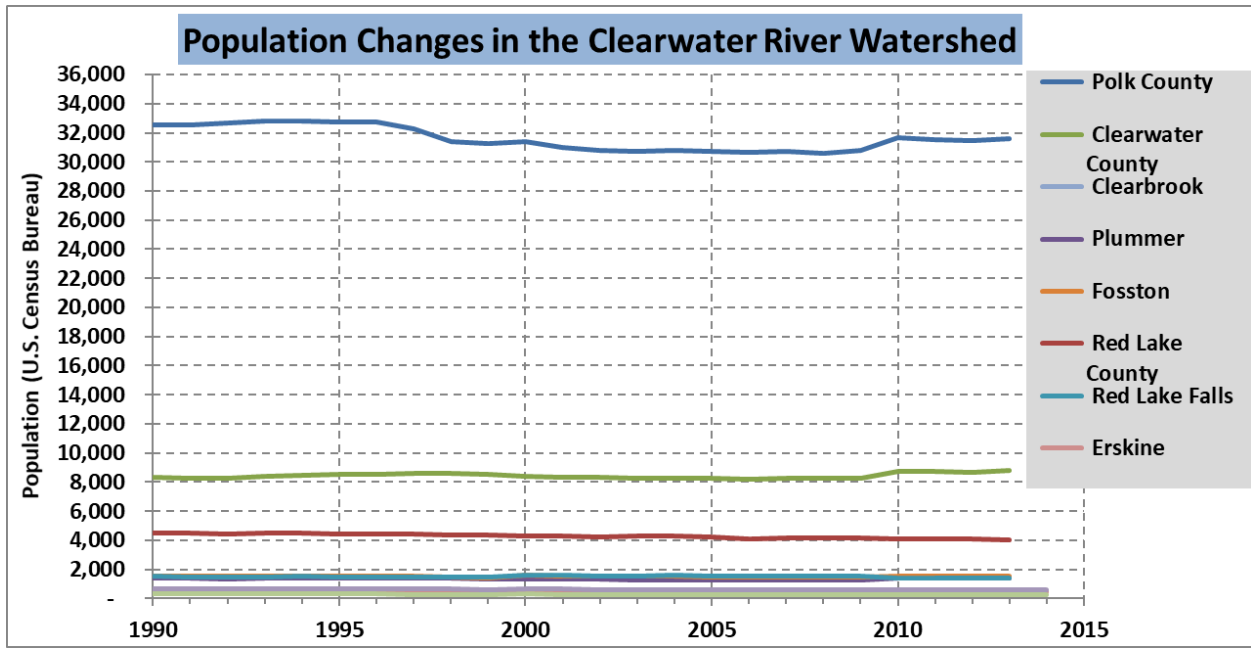
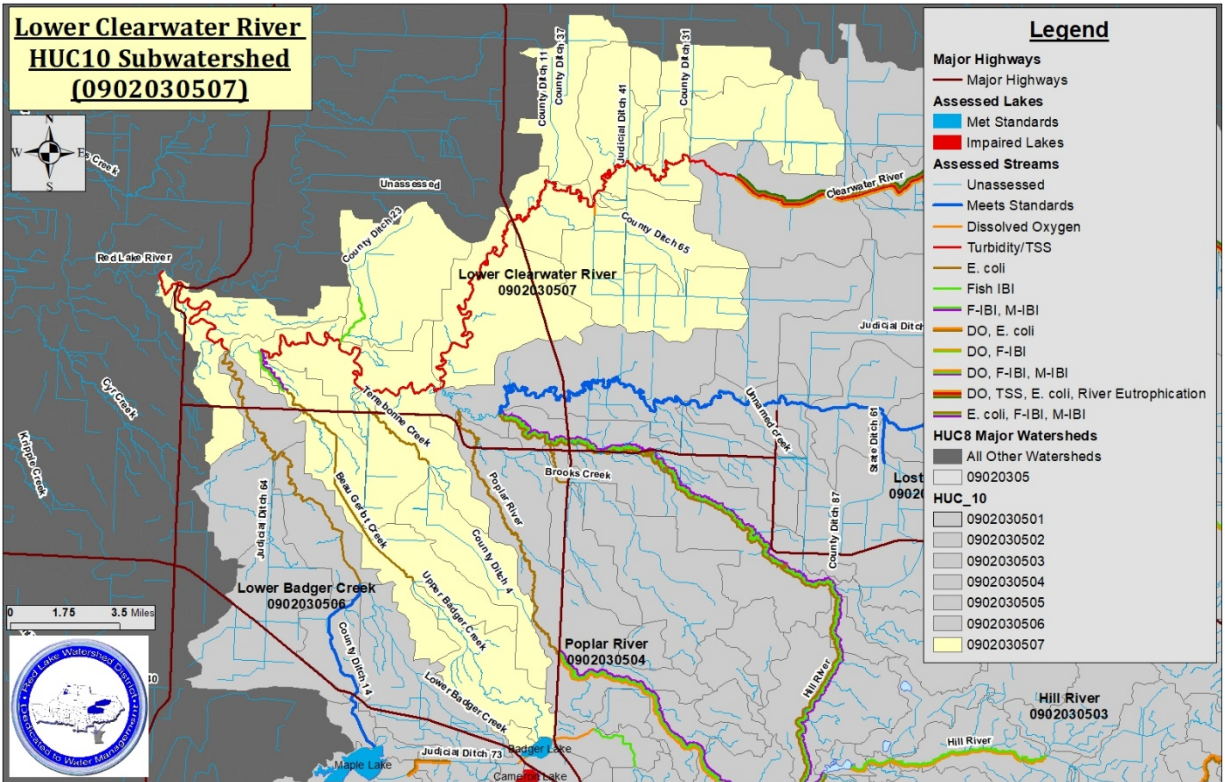

Grand Marais Creek Watershed Restoration and Protection Strategy (WRAPS)

A revised map of existing Grand Marais Creek watershed impoundments was created for the reports.

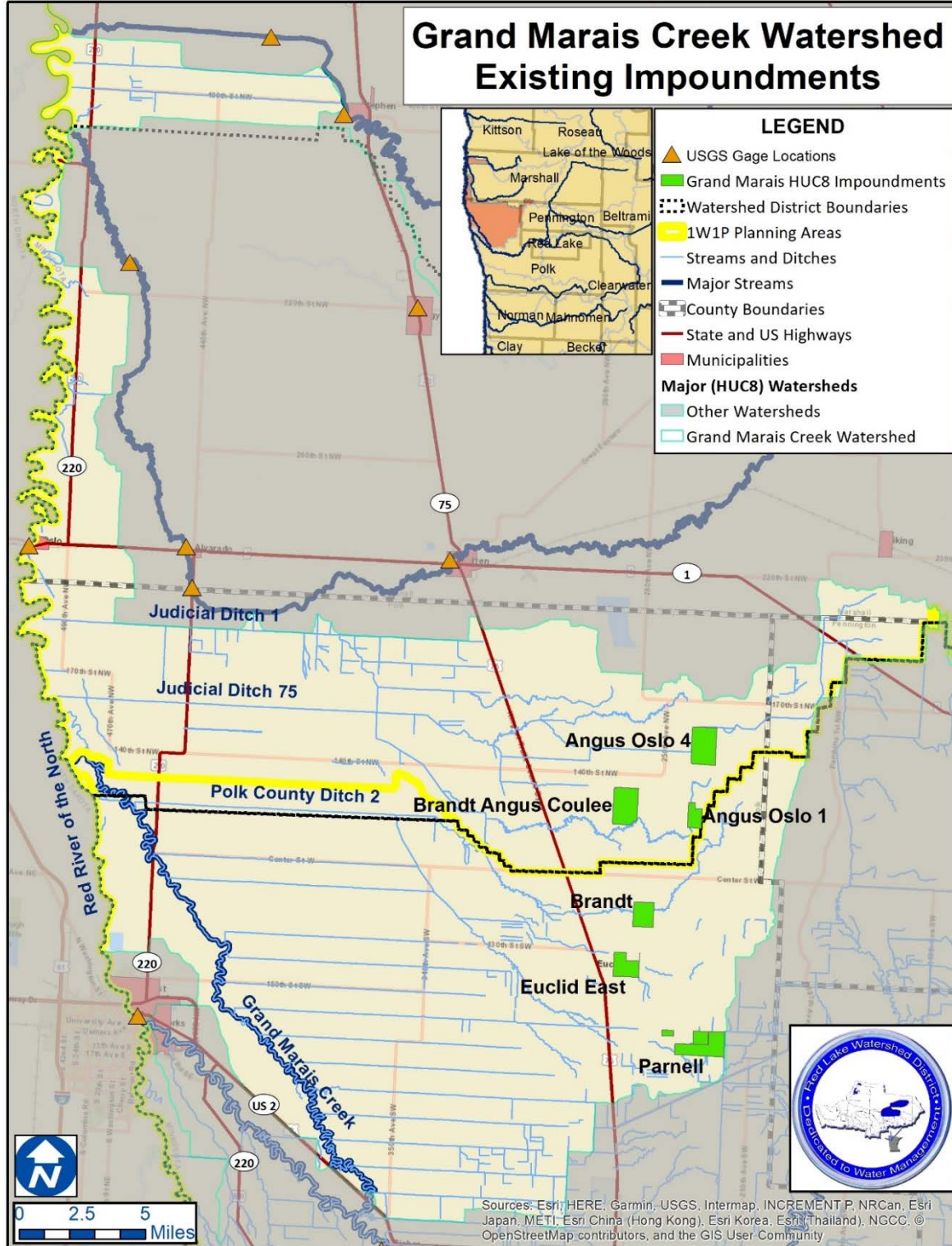

Red Lake River Watershed Restoration and Protection Strategy (WRAPS)

Comments were received from the MPCA and EPA on the Red Lake River Total Maximum Daily Load (TMDL) report on 10/31/2018, so editing of that document began in early November. The map and table of impaired were revised so that they reflected changes (delistings and recategorizations) that were made in the 2018 Draft List of Impaired waters (compared to the 2016 Draft List of Impaired Waters).

Other map revisions included:

- Land use
- Drainage areas of impaired waters
- Kripple Creek fish, macroinvertebrate, and habitat scores (AUIDs 098020303-525 and -526)
- JD 60 subwatershed map
- Cyr Creek fish, macroinvertebrate, and habitat scores
- Black River longitudinal dissolved oxygen

A chart showing the seasonality of total suspended solids was revised. The spreadsheets that were used for the calculation of total maximum daily loads were provided to the MPCA Project Manager and MPCA engineers. All of the sections in the report were reviewed for grammar, spelling, and clarity. The Cyr Creek and Gentilly Creek TMDLs were revised with updated flow records. Industrial and construction stormwater wasteload allocations were added to all total suspended solids TMDLs.

RLWD and MPCA staff discussed the possibility of designating the City of Thief River Falls as an MS4 (Municipal Separate Storm Sewer). The MS4 and MNDOT Right of Way stormwater wasteload allocations for the cities of East Grand Forks and Crookston were calculated, incorporated into TMDLs, and summarized.

A revised draft of the Red Lake River TMDL was completed and sent to the MPCA Project Manager on December 7, 2018. An edited TMDL summary section for the Red Lake River WRAPS was also completed and sent to the MPCA Project Manager.

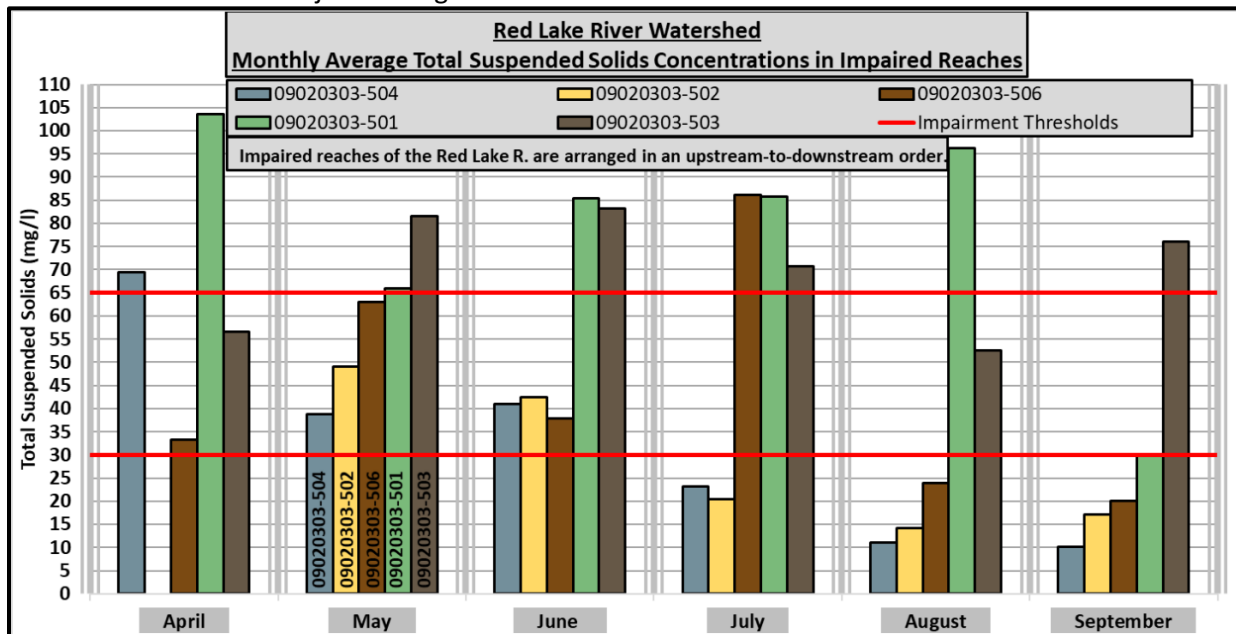

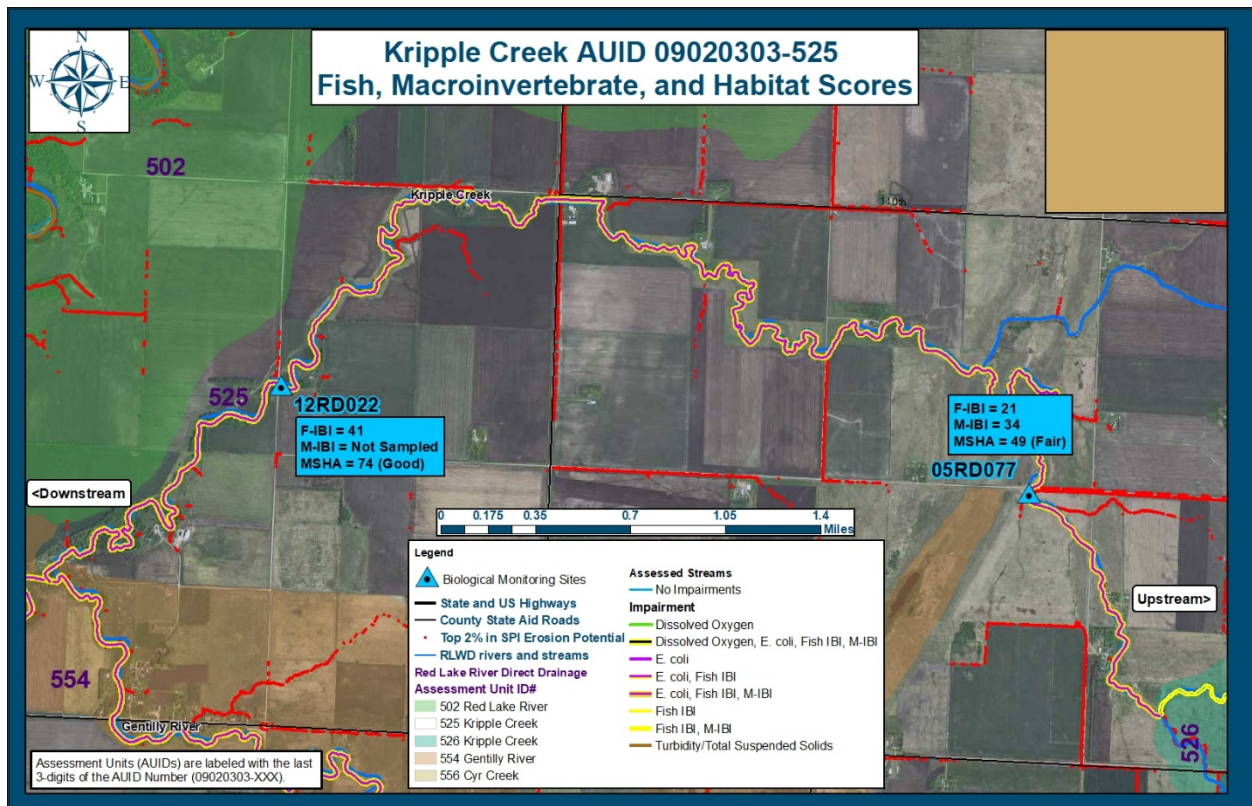
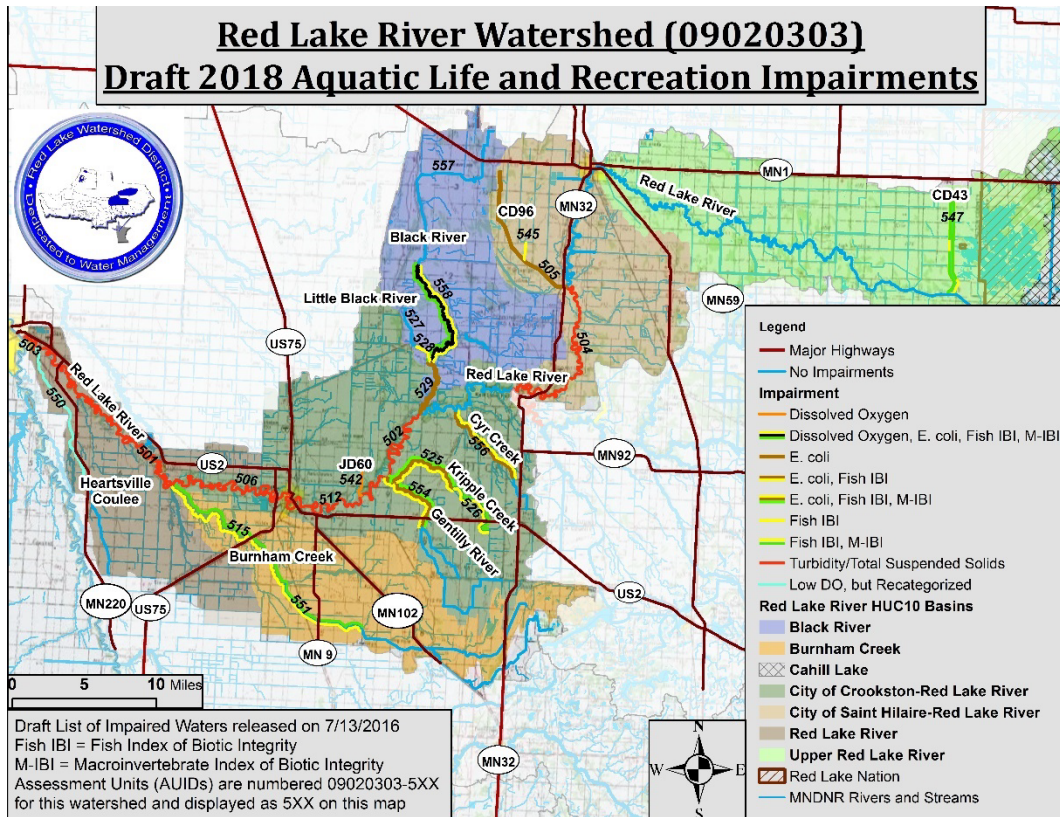

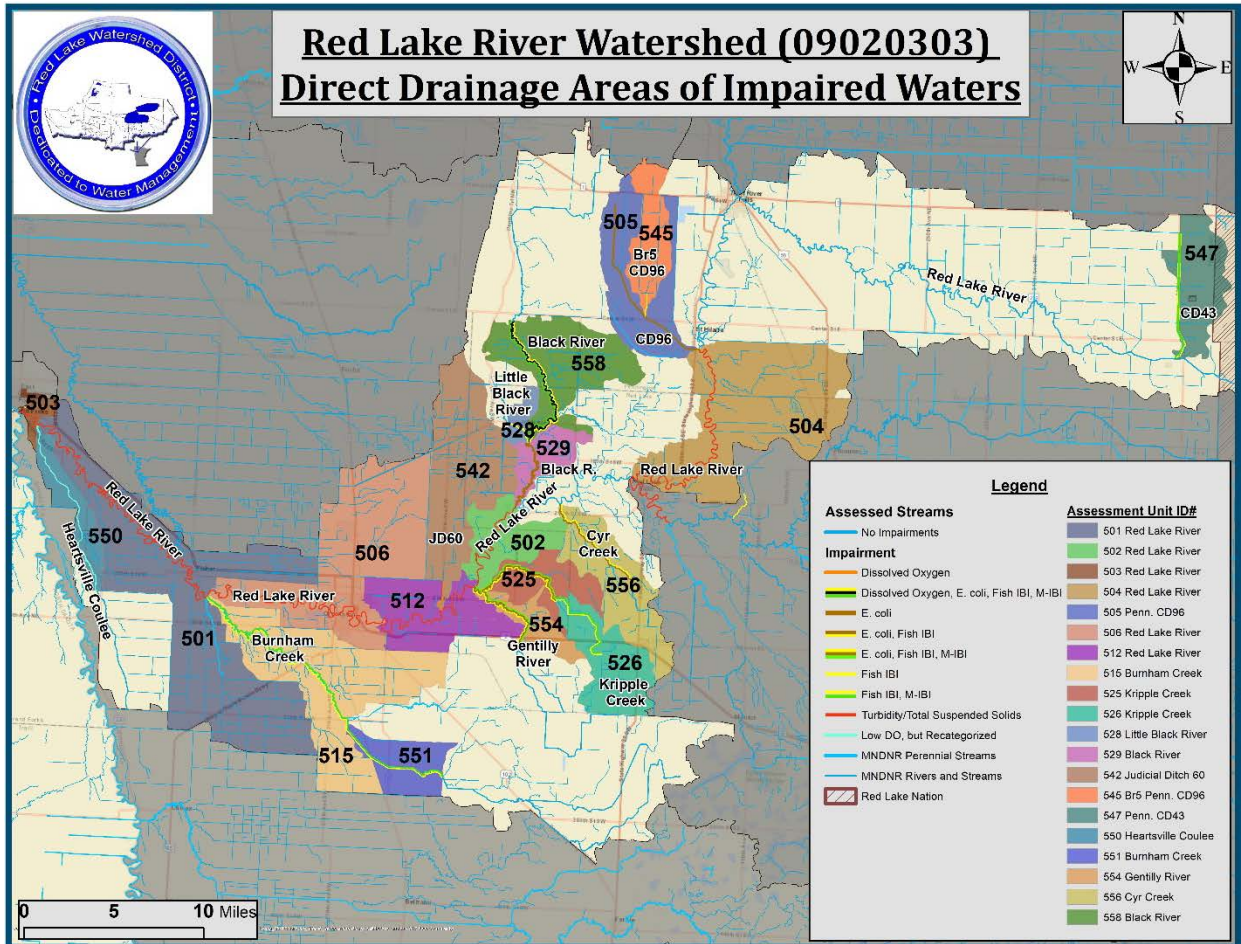

Thief River One Watershed One Plan (1W1P)

A Planning Work Group phone conference was held on November 2, 2018. RLWD staff prepared an informational presentation about the findings of the Thief River WRAPS to be presented at a Thief River 1W1P meeting. RLWD staff reviewed a draft Section 5 of the Thief River 1W1P. A meeting of advisory committees and the policy committee was held on November 14, 2018 in Grygla. District staff updated the Thief River 1W1P website. A Planning Work Group meeting was held on December 5, 2018 to discuss the targeted implementation schedule tables of Section 4. A meeting of advisory committees and the policy committee was held on December 12, 2018 at the RLWD office.

Red Lake River One Watershed One Plan

A Planning Work Group phone conference was held on November 1, 2018. RLWD staff reviewed a targeted implementation plan for the Red Lake River planning area that was developed by Houston Engineering using an updated version of the Red Lake River PTMApp model. A Planning Work Group meeting was held in Red Lake Falls to discuss methods for tracking progress and targeted Regional Conservation Partnership Program (RCPP) funding.

Other Notes

- Water quality related notes from the November 8, 2018 Red Lake Watershed District Board of Managers meeting:
 - Darren Carlson, Marshall County SWCD, stated that in 2017 the SWCD installed side water inlet (SWI) culverts within the District's boundary which were in part, funded with the assistance from the District's Erosion Control Funds, RLWD Project No. 164. Carlson requested additional funding from the 2018 Erosion Control Funds, RLWD Project No. 164, in the amount of \$12,500 to assist in the design of the structures and installation of SWI culverts located within the District's boundary. The Board voted and approved the cost share funding in the amount of \$12,500 to assist in the design and installation of side water inlet culverts for the Marshall County SWCD.
 - The Pennington SWCD was featured in a Minnesota Board of Water and Soil Resources newsletter: SWCD Managers Collaborate to Solve Problems, Save Money. <http://www.bwsr.state.mn.us/news/webnews/november2018/3.pdf>
- Water quality related notes from the November 27, 2018 Red Lake Watershed District Board of Managers meeting:
 - Chester Powell, Clearwater SWCD, appeared before the Board to request funding assistance for Clearwater County to complete 3D aerial imaging of Clearwater County. Mr. Powell indicated that the estimated cost of the aerial imagery is \$75,375. Clearwater SWCD was awarded a grant through BWSR, but it did not cover all cost for the 3D aerial imaging project. Mr. Powell stated that funds from Wild Rice Watershed District and Clearwater County have been secured contingent upon funding from the District. Upon questions from the Board, Mr. Powell indicated that he would like to request funding from the District in the amount of \$7,537.50 which would assist in funding the shortfall. Motion by Page, seconded by Sorenson, to approve cost-share in the amount of \$7,537.50, with the Clearwater SWCD to complete 3D aerial imaging in Clearwater County. Motion carried.
 - Additional discussion was had with Chester Powell, Clearwater SWCD, concerning buffer compliance in Clearwater County. Mr. Powell stated all ditches in Clearwater County are in compliance with the new buffer law. Powell further noted that the SWCD just completed installation of four side water inlets that were partially funded by the District.
- Water quality related notes from the December 13, 2018 Red Lake Watershed District Board of Managers meeting:
 - Craig Mowry, Agassiz National Wildlife Refuge (NWR) appeared before the Board to update the Board on the current Conservation Partners Legacy Grant from the Lessard Sam Heritage Council that the District had applied for on behalf of Agassiz NWR in the amount of \$242,000, with matching funds in the amount of \$46,400 from Agassiz NWR. Mowry stated that the grant allowed for spraying of 2,000 acres of cattails within the refuge, for a total of 8,448 acres of cattails sprayed since 2010. The grant also included repairs to a water control structure which was recently completed by Triple D Contractors. Agassiz NWR hired an amphibious excavator, which cleaned out ditches within the refuge that were full of silt. The balance of the current grant will be spent in the fall of 2019, with the replacing of two rusted out corrugated pipes with a large box culvert. Mowry requested assistance to administer an additional grant from the

Lessard Sam Heritage Council for a Conservation Partners Legacy grant for \$50,000 to restore wetland function with the refuge. Agassiz NWR would be required to have a 10% match for the grant. The District would be appropriating funds in to administer the grant. Mowry discussed the efforts of the refuge to reduce sediment and nutrient loading within the Thief River Watershed. Motion by Ose, seconded by Tiedemann, to approve the partnership and administration of a \$50,000 grant for Agassiz National Wildlife Refuge from the Lessard Sam Heritage Council Conservation Partners Legacy Grant. Motion carried.

- Note: The excavation and flushing of sediment from the old JD 11 channel through Agassiz Pool has caused alarmingly high increases in turbidity and TSS downstream in the Thief River. It has also caused sedimentation within the State Ditch 83 portion of the Thief River. Discharge from Agassiz Pool during drawdowns and flushing of sediment has led to violations of drinking water safety standards in Thief River Falls (excess trihalomethanes).
- RLWD staff reviewed and provided comments on a draft letter from the Red River Watershed Management Board to the MPCA regarding a public comment period on Tiered Aquatic Life Use (TALU) classifications.
- RLWD staff provided assistance with a grant proposal from the Gully Co-op for a project that will implement BMPs in wild rice paddies.
- A May 2018 water quality report was completed and posted online:
<http://www.redlakewatershed.org/waterquality/MonthlyWQReport/2018%2005%20May%20Water%20Quality%20Report.pdf>
- A June 2018 water quality report was completed and posted online:
<http://www.redlakewatershed.org/waterquality/MonthlyWQReport/2018%2006%20June%20Water%20Quality%20Report.pdf>
- A July 2018 water quality report was completed and posted online:
<http://www.redlakewatershed.org/waterquality/MonthlyWQReport/2018%2007%20July%20Water%20Quality%20Report.pdf>
- RLWD staff reviewed proposed legislative changes to the Clean Water Legacy Act regarding coordinated watershed management plans (comprehensive watershed management plans and one watershed one plans) at the request of the Red River Watershed Management Board's lobbyist.
- The Pennington Soil and Water Conservation District was awarded \$542,642 in Clean Water Funds from the Minnesota Board of Water and Soil Resources (BWSR) for their proposed Thief River Falls Streambank Stabilization Projects project:
 - Three streambank stabilization projects have been identified as high priority projects in the Thief River Falls Water Quality Study completed in 2017. The proposal will use a combination of bendway weirs, toe protection by building a floodplain bench and live stake plantings. It has been estimated that a total of 385 tons per year of sediment from these three locations is entering the river contributing to the impairment downstream.
- The RLWD application for BWSR Clean Water Funds for stabilization of the outlet of the Westside FDR Project and the East Polk SWCD application for Clearwater River watershed Water and sediment control basins were unsuccessful in this round of funding.
- RLWD staff provided MPCA staff with 2018 flow data from the Gentilly River.
- Dave Friedl (DNR, retired) shared gage analysis of the Thief River. The analysis determined that bankfull height was approximately 1,100 CFS. That flow rate could be used as a reference point

when discussing discharge rates from impoundments. Keeping in-stream flow rates below that level would help reduce erosion along the river.

Meetings and Events from November and December 2018

- **November 1, 2018** – Red River Basin Monitoring Advisory Committee Meeting
 - Red River Basin Monitoring Situation – MPCA Monitoring and Assessment
 - Andrew Butzer discussed Watershed Pollutant Load Monitoring and Data Products.
 - In reference to some questions about whether or not Watershed Pollutant Load Monitoring Network (WPLMN) sampling (which targets higher flows) introduces a bias that could be considered during water quality assessments, a meeting attendee noted that mean flow from sampling dates could be compared to the overall mean daily flow in order to identify bias.
 - MPCA and International Water Institute staff have been using the CANVAS app for recoding data during the WPLMN sampling. Entering the data adds 15-20 minutes per site.
 - Data can be accessed and analyzed online (including FLUX modeling results) through TABLEAU.
 - Scott Niemala discussed MPCA biological monitoring, TALU, and the second cycle of the Intensive Watershed Monitoring and Watershed Restoration and Protection Strategy processes.
 - During the second cycle of monitoring and assessment, sites that didn't work well will not be re-sampled. There will probably be less money available for monitoring. Surface Water Assessment Grant sites that would create a duplication of existing sampling efforts could also be cut.
 - Local partners will be engaged prior to monitoring, in response to comments that were submitted. More people are buying into the process. Getting locals involved in early stages will be helpful.
 - Stressors and pollutants will be identified. There will, hopefully, be some opportunities for delistings.
 - The planning process for the second cycle of monitoring and assessment in the Thief River Watershed will begin in 2020.
 - Red River Basin MAC Organization
 - MAC Meeting Schedule
- **November 14, 2018** – Thief River One Watershed One Plan Advisory Committee and Policy Committee meetings
- **December 3, 2018** – Red Lake River One Watershed One Plan Planning Work Group meeting
 - Much of the discussion at this meeting focused on potential methods for tracking planned/completed projects and progress toward goals of the Red Lake River 1W1P.
 - RCPP funding for priority areas (\$428,000 over three years) was also discussed. Priority areas and a set of screening questions will need to be selected for this funding.
- **December 10, 2018** – Polk County Water Resources Advisory Committee meeting at the Valley Technology park in Crookston

- Efforts to control aquatic invasive species in the county have included the purchase of 5 sets of tools for cleaning boats and trailers along with youth education and essay contests. There was discussion about blue-green algae.
- Polk County staff reported that 98% of the East Polk SWCD portion of the county is in compliance with the buffer law.
- The We Are Water exhibit will be at the University of Minnesota Crookston from January 21 -March 4, 2019.
- There was discussion about educational workshops about lakescaping, rain barrels, and/or rain gardens. A public demonstration project might be helpful. A lakescaping project has been completed at the Union Lake/Sarah campground.
- **December 12, 2018** – Red Lake River One Watershed One Plan PTMApp close-out meeting
- **December 14, 2018** – Red River Basin Monitoring Advisory Committee meeting
 - Red River Basin MAC Organization – Planning Committee Outcomes
 - Red River Basin Member Updates
 - The International Water Institute has assembled a Story Map Gallery of flood damage reduction projects:
<http://www.arcgis.com/apps/PublicGallery/index.html?appid=742ffba9bf2e4190b7254a720fb2ebdf>.
 - International Water Institute staff shared information about the River of Dreams educational canoe launch program (www.riverofdreams.org). They are looking for a non-toxic, yet durable alternative to the epoxy that is used to protect the informational tag “inside” the canoes.
 - The International Water Institute has been conducting pesticide sampling at Minnesota Department of Agriculture Tier 1 and Tier 2 locations. They are trying to collect samples after runoff events.
 - Some River Watch programs have started using DIY kits to conduct continuous monitoring at 8 locations throughout the Red River Basin. They are looking for locations that are close to a school, have adequate sunlight for the solar panels, need data, and are safe from vandalism.
 - There was an update on Watershed Pollutant Load Monitoring Network sampling that has been conducted by the International Water Institute.
 - The MPCA has been conducting hydrologic monitoring at 22 stations throughout the Red River Basin. They have upgraded sensors to radar in some watersheds. Flow measurements are being conducted once per month. Telemetry is being added to sites in the Otter Tail River Watershed. New stations with velocity meters (concern about backwater) have been added to the Blackduck and Tamarac Rivers.
 - MPCA sondes will be upgraded to YSI EXO2s as the YSI 6920 and 6820 sondes will be phased-out.
 - Sondes may be available for agencies that want to do monitoring.
 - The International Water Institute commissioned a painted map of the Red River Basin, by Laura Salmela.

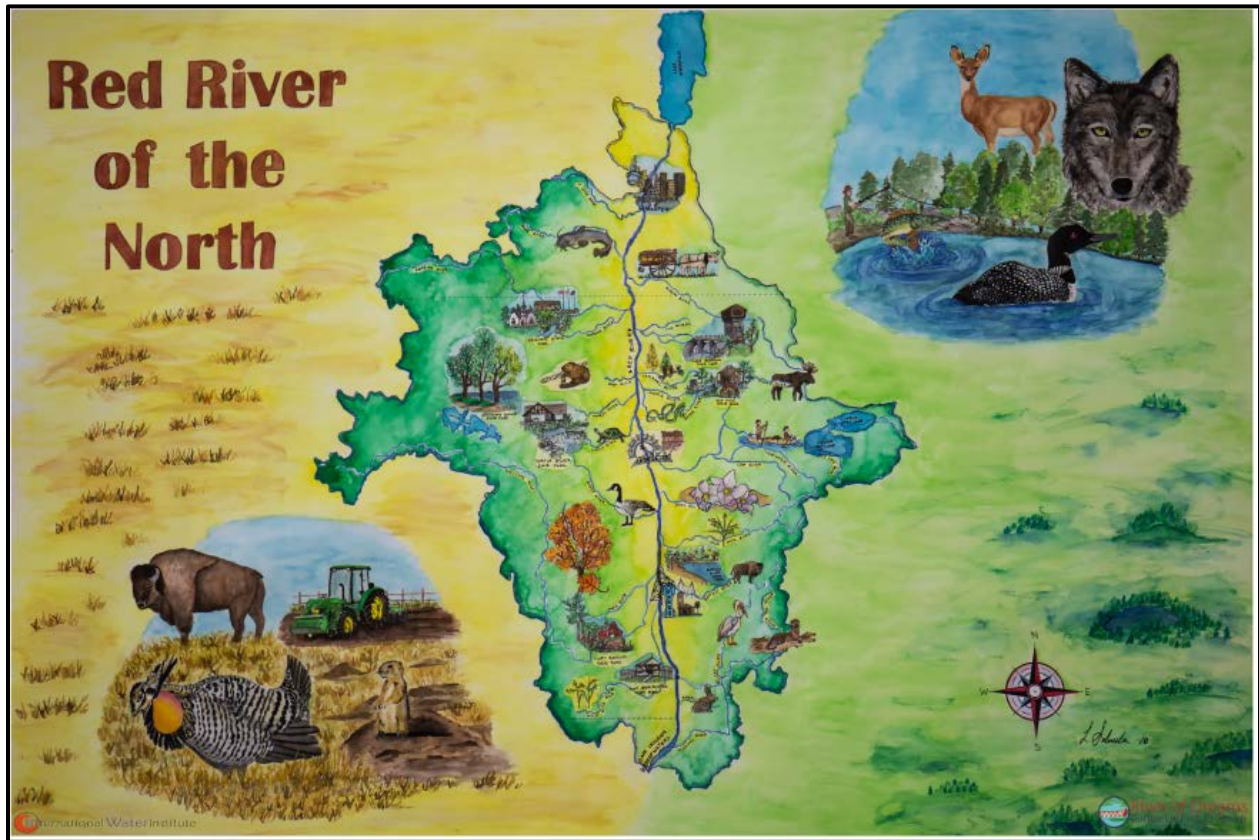

- Red River Basin Monitoring Training – Group Discussion and Decision
- The state is transitioning from HYDSTRA to WISKI for storage of continuous monitoring data (data from flow and dissolved oxygen loggers).
- Brandt Impoundment Story Map (Page 1 of 5):

Brandt Impoundment - Project 60D International Water Institute

1 2 3 4 5

Brandt (Project 60D) Background
The Brandt Impoundment project (RLWD Project 60D) is located in Section 7 of Belgium Township in Polk County. It is approximately 14 miles north of Crookston and just northeast of Euclid, about a mile and a half east of U.S. Highway 75.

[View a pre-project aerial photo.](#)

Project Purpose
The Brandt Project was designed to reduce downstream agricultural and urban flood damages by retaining up to 3,912 acre-feet of excess runoff from the upstream drainage area. This impoundment facility is intended to reduce peak discharges on the downstream Brandt Channel (legal County Ditch #2) system.

[View a project design image.](#)

Project Components
The embankment and reservoir is constructed of approximately 3.5 miles of earthen clay (492,579 cubic yards with a max height of up to 19 feet in height), a grass lined emergency spillway, 2 lines of 6 x 8 concrete box culverts, and a gated concrete outlet structure. The gated structure releases water from the impoundment into an outlet channel. This water then flows west-northwest through the Brandt Channel system and eventually to the Red River of the North.

Feature	Measurement	Storage (acre-ft.)
Top of Dam (Total Storage)	918.0 Ft. mas.	3,912 (3.7 in runoff)
Secondary Spillway	914.5 Ft. mas.	-
Ungated Storage to Emergency Spillway	916.0 Ft. mas.	780 (0.82 in runoff)
Stated Storage	-	3,126 (3.48 in runoff)
Drainage Area	23.6 Sq. Mile	-

The project became operational in the spring of 2008. The Red Lake Watershed District and HDR Engineering of Thief River Falls jointly performed construction, surveying, and inspection duties.

*Note: Outline is meant to draw attention to impoundment area and does not mark the impoundment boundary.

USDA, FSA, DigitalGlobe, GeoEye, Earthstar/Earthstar, CNES/Airbus DS, USDA, Esri, AeroGRID, IGN, and the GIS User Community

esri

○ Euclid East Impoundment Story Map (Page 1 of 5):

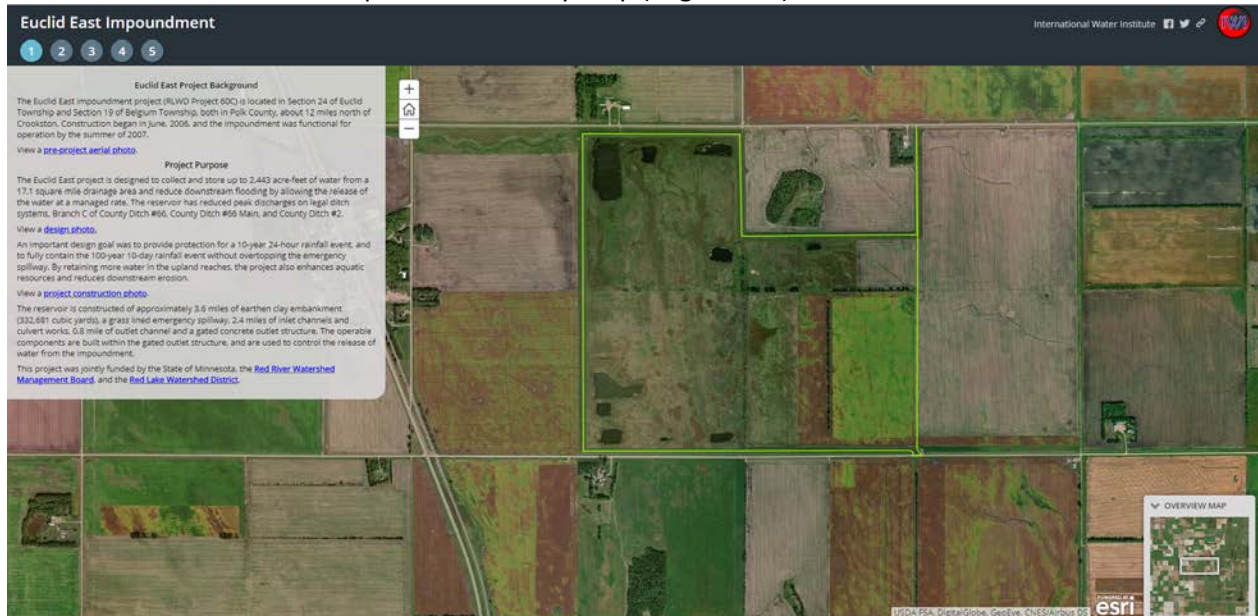

- **December 20, 2018** – Meeting at the Grand Rapids DNR office with BWSR about the One Watershed One Plan processes and potential Regional Conservation partnership Program (RCPP) funding from the NRCS that will be directed toward priority watershed that were identified in 1W1Ps.
 - Your Experience: from planning to implementation
 - Data-based prioritization
 - Templates would be helpful
 - Having a neutral facilitator is important.
 - When do we start thinking about the next round?
 - Assurance measures
 - Discussion about invoicing and making sure that partners know how much they can invoice and for what.
 - Make sure that the plan will still function through changeover in staff or policy committee members.
 - Plan for social marketing.
 - Grants are reviewed against criteria.
 - The 1W1P replaces competitive grant application and review processes.
 - There will be a decrease in competitive grant funding as the amount of non-competitive 1W1P funding increases.
 - Develop easy-to-understand metrics to measure progress toward goals, based upon the workplan (High Performance = meet or exceeded goals; Successful = met most of the goals; Needs Improvement = little to no progress)
 - Try to think of ways to maximize the amount of water quality improvement that comes from “other people” through education and marketing.
 - A challenge in the northeastern portion of Minnesota is that waters are already in good condition (all protection, little restoration). Use other metrics in addition to water quality (index of biological integrity, Minnesota Stream Habitat Assessment).

- 80% of funds should be spent on activities that address priority clean water issues in targeted areas. There was some discussion about whether or not education, outreach, plan administration, and coordination should factor into this equation.
- It has been difficult to come up with practical metrics for education.
- Documentation is important, even where we fail to meet goals. Are there areas where landowners don't want to participate and we have to move on to the next priority area?
- RCPP next steps
 - Local planning workgroups determine the ranking questions.
 - Federal funds available for EQIP BMP implementation in targeted areas.
 - The Red Lake River was one of the watersheds that were selected for this program.

Red Lake Watershed District Monthly Water Quality Reports are available online:
<http://www.redlakewatershed.org/monthwq.html>.

Learn more about the Red Lake Watershed District at www.redlakewatershed.org.

Learn more about the watershed in which you live (Red Lake River, Thief River, Clearwater River, Grand Marais Creek, or Upper/Lower Red Lakes) at www.rlwdwatersheds.org.

"Like" the Red Lake Watershed District on [Facebook](#) to stay up-to-date on RLWD reports and activities.